



BBV 1-2-1 Protocol Converter



Installation Guide



BBV single camera protocol converter



Building Block Video Ltd
17 Apex Park,
Diplocks Industrial Estate,
Hailsham, East Sussex, BN27 3JU, UK
Tel: + 44 (0) 1323 842727
Fax: +44 (0) 1323 842728
www.bbvctv.com

Version 36.2

This manual covers BBV single channel protocol converter
software version **CONV3_V36**

Table of content.

Compatible Protocols	4	FORWARD VISION MIC-1300/400 from BBV telemetry	20	VCL TP	34
Fig 1 PCB Layout	5	JVC TK-C676 – Fixed at 9600,E,8,1	22	VCL TP – from 360 Vision Protocol	34
Fig 2 System Layout	6	LG DOME (PELCO D) from BBV telemetry	22	Vicon Surveyor from BBV telemetry	35
Address numbering	7	MARK MERCER from BBV telemetry	23	VIDECON VCP451 CAMERA from BBV telemetry	36
Output Protocol & Baud Selection	8	MARK MERCER from VICON telemetry	23	VIDECON VHSD 860 DOME from BBV telemetry	37
RS232 serial port	11	Meyertech ZVR-510 receiver with VICTA protocol from BBV telemetry	24	VIDEOTECH ULISSE (PELCO D) from BBV telemetry	38
Supported input and output protocols	12	Molynx protocol – Fixed at 9600,E,8,1 Control from BBV telemetry	25	Vista PowerDome from BBV telemetry	39
360 VISION from BBV telemetry	13	NIO D86/Interceptor (PELCO D) from BBV telemetry	26		
360 VISION from VCL telemetry	14	PANASONIC WV-CS850/860 from BBV telemetry	27		
Chugai SMD20, STAR MD2000, SANYO VCC9200P from BBV telemetry	15	PELCO P and PELCO D	28		
Chugai/Ganz ZC-S122/123 – Fixed at 9600,E,8,1	16	Philips RS232/485 from BBV telemetry	29		
CONWAY dome from BBV telemetry	17	PHOTOSCAN FIXED SPEED PAN/TILT from BBV telemetry	30		
COP PELCO D or PELCO P from BBV telemetry	18	Samsung SCC641/643 dome and SCC421 camera from BBV telemetry	31		
DENNARD 20xx – Fixed at 9600,N,8,1	18	Sensormatic RS422 from BBV telemetry	32		
DM DTMF RECEIVERS USING TAD3 from BBV telemetry	19	VCL TP – Fixed at 9600,N,8,1	33		

Protocols compatible with the BBV 1-2-1 converter:

360 Vision	Panasonic CS850/860
BBV RX450/550	Pelco D
CBC SMD20	Pelco P
Chugai	Philips RS232/485 (bi-phase via Philips LTC8780/50)
Conway	Photoscan fixed speed pan/tilt
COP (Pelco D or P)	Samsung 641/643 dome 421P camera
Dennard 2050	Sanyo VCC9200P
DM DTMT (using TAD3 with special s/w)	Sensormatic RS422 (Ultradome)
Forward Vision Mic1-300/400	Star MD2000
Ganz ZC-S122/123	VCL
JVC 676	Vicon Surveyor & V1305DC
LG dome (Pelco D)	Videcon VHSD860 Dome (Pelco P-9600,N,8,1)
Mark Mercer	Videcon VPC451 Camera (Pelco D-2400,N,8,1)
Meyertech ZVR510 VICTA protocol	Videotec Ulisse (Pelco D)
Molynx 250/260	Vista PowerDome
NIO D86/Interceptor (Pelco D)	

BBV 1-2-1 converter Manual Version History

V36.2 15 July 10 1 **Change text on page 5 SW3 read output and changed BBV485 for BBV422**
V36.1 15 June 10 1 Change text on page 30 to read SW1/3&4 instead of SW3 & SW4
V36 28 May 10 1. Release of the BBV single channel protocol 1-2-1 converter

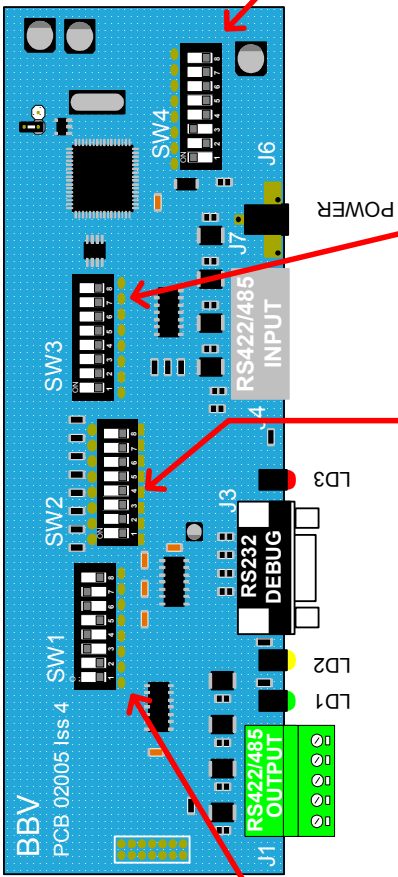

LED guide

- GREEN LD1 - data IN
- YELLOW LD2 - data ERROR
- RED LD3 - data OUT

SW1 - termination

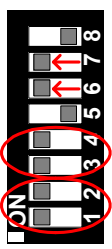

- 1/2** ON DATA In Termination
- ON Terminated
- 3/4** ON DATA Out Termination
- ON Terminated
- 5 Not used
- 6/7** **MUST BE ON**
- 8 Not used

SW2 address selection.

For settings see page 7.

SW3 input protocol

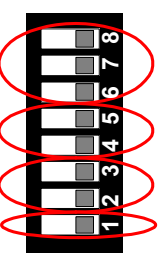

SW4 output protocol.
For settings see page 9.

6 - 8 Protocol Selection		2 - 3 Parity	
8	OFF	6	OFF
7	OFF	4	OFF
6	OFF	3	OFF
	ON	2	OFF
	ON		NONE
	ON		EVN
	ON		ODD
	ON		NONE

4 - 5 Baud		2 - 3 Parity	
5	OFF	3	OFF
4	OFF	2	OFF
	ON		EVN
	ON		ODD
	ON		NONE

- 1 Data bits
- OFF 8 BITS
- ON 7 BITS

Fig 1 PCB Layout

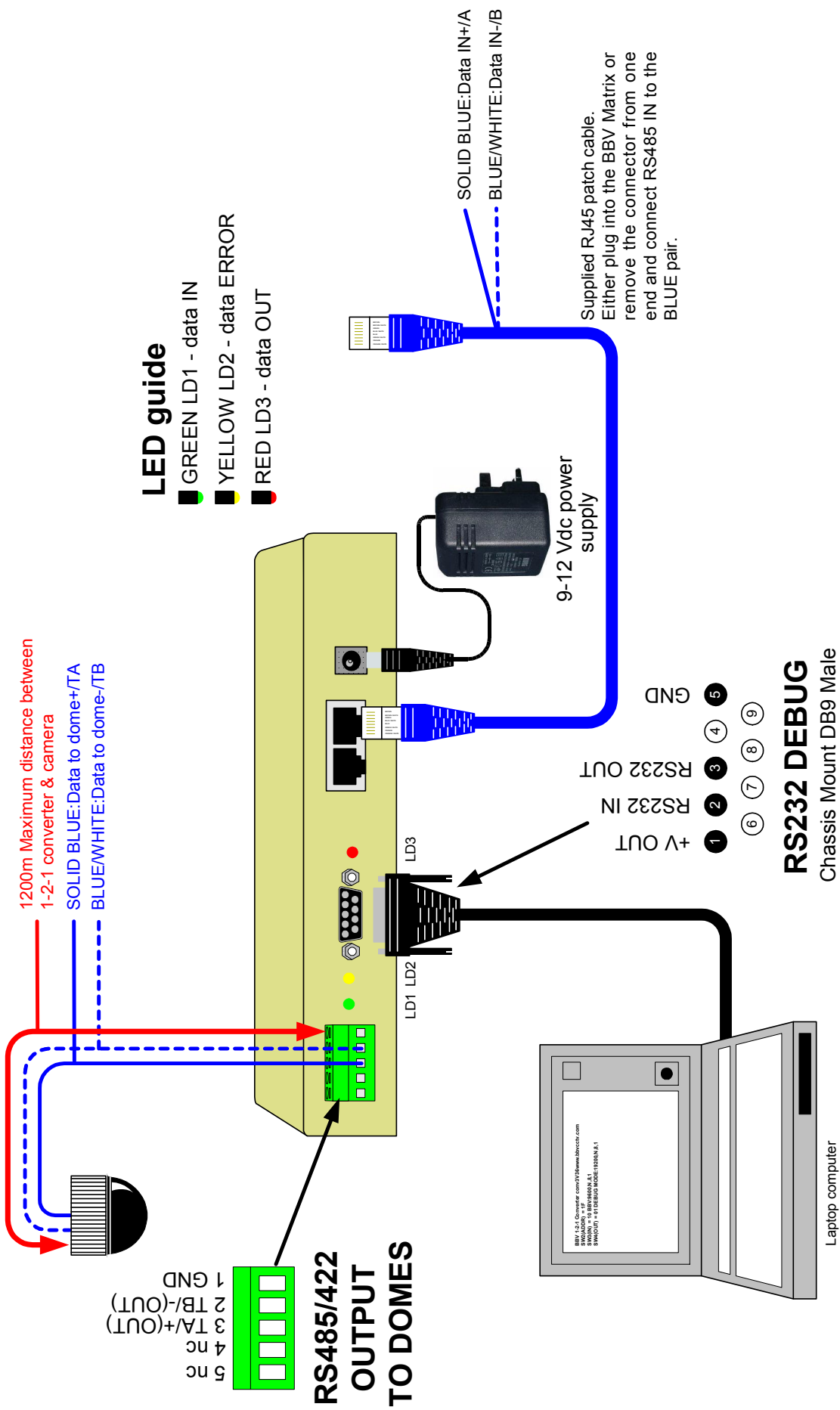

Fig 2 System Layout

Address numbering

Address numbering is limited to the number of addresses supported by the selected protocol; the maximum number of addresses that can be supported is 128. For example, a protocol that supports 256 addresses would support a maximum of 128 addresses when used with the 1-2-1 converter.

Camera address selection SW2								Camera
128	64	32	16	8	4	2	1	
SW8	SW7	SW6	SW5	SW4	SW3	SW2	SW1	
OFF	OFF	OFF	OFF	OFF	OFF	OFF	OFF	1.
OFF	OFF	OFF	OFF	OFF	OFF	OFF	ON	2.
OFF	OFF	OFF	OFF	OFF	OFF	ON	OFF	3.
OFF	OFF	OFF	OFF	OFF	OFF	ON	ON	4.
OFF	OFF	OFF	OFF	OFF	ON	OFF	OFF	5.
OFF	OFF	OFF	OFF	OFF	ON	OFF	ON	6.
OFF	OFF	OFF	OFF	OFF	ON	ON	OFF	7.
OFF	OFF	OFF	OFF	OFF	ON	ON	ON	8.
OFF	OFF	OFF	OFF	ON	OFF	OFF	OFF	9.
OFF	OFF	OFF	OFF	ON	OFF	OFF	ON	10.
OFF	OFF	OFF	OFF	ON	OFF	ON	OFF	11.
OFF	OFF	OFF	OFF	ON	OFF	ON	ON	12.
OFF	OFF	OFF	OFF	ON	ON	OFF	OFF	13.
OFF	OFF	OFF	OFF	ON	ON	OFF	ON	14.
OFF	OFF	OFF	OFF	ON	ON	ON	OFF	15.
OFF	OFF	OFF	OFF	ON	ON	ON	ON	16.
OFF	OFF	OFF	ON	OFF	OFF	OFF	OFF	17.
OFF	OFF	OFF	ON	OFF	OFF	OFF	ON	18.
OFF	OFF	OFF	ON	OFF	OFF	ON	OFF	19.
OFF	OFF	OFF	ON	OFF	OFF	ON	ON	20.
OFF	OFF	OFF	ON	OFF	ON	OFF	OFF	21.
OFF	OFF	OFF	ON	OFF	ON	OFF	ON	22.
OFF	OFF	OFF	ON	OFF	ON	ON	OFF	23.
OFF	OFF	OFF	ON	OFF	ON	ON	ON	24.
OFF	OFF	OFF	ON	ON	OFF	OFF	OFF	25.
OFF	OFF	OFF	ON	ON	OFF	OFF	ON	26.
OFF	OFF	OFF	ON	ON	OFF	ON	OFF	27.
OFF	OFF	OFF	ON	ON	OFF	ON	ON	28.
OFF	OFF	OFF	ON	ON	ON	OFF	OFF	29.
OFF	OFF	OFF	ON	ON	ON	OFF	ON	30.
OFF	OFF	OFF	ON	ON	ON	ON	OFF	31.
OFF	OFF	OFF	ON	ON	ON	ON	ON	32.
OFF	OFF	ON	OFF	OFF	OFF	OFF	OFF	33.
OFF	OFF	ON	OFF	OFF	OFF	OFF	ON	34.
OFF	OFF	ON	OFF	OFF	OFF	ON	OFF	35.
OFF	OFF	ON	OFF	OFF	OFF	ON	ON	36.
OFF	OFF	ON	OFF	OFF	ON	OFF	OFF	37.
OFF	OFF	ON	OFF	OFF	ON	OFF	ON	38.
OFF	OFF	ON	OFF	OFF	ON	ON	OFF	39.
OFF	OFF	ON	OFF	OFF	ON	ON	ON	40.
OFF	OFF	ON	OFF	ON	OFF	OFF	OFF	41.
OFF	OFF	ON	OFF	ON	OFF	OFF	ON	42.
OFF	OFF	ON	OFF	ON	OFF	ON	OFF	43.
OFF	OFF	ON	OFF	ON	OFF	ON	ON	44.
OFF	OFF	ON	OFF	ON	ON	OFF	OFF	45.
OFF	OFF	ON	OFF	ON	ON	OFF	ON	46.
OFF	OFF	ON	OFF	ON	ON	ON	OFF	47.
OFF	OFF	ON	OFF	ON	ON	ON	ON	48.
OFF	OFF	ON	ON	OFF	OFF	OFF	OFF	49.
OFF	OFF	ON	ON	OFF	OFF	OFF	ON	50.
OFF	OFF	ON	ON	OFF	OFF	ON	OFF	51.
OFF	OFF	ON	ON	OFF	OFF	ON	ON	52.
OFF	OFF	ON	ON	OFF	ON	OFF	OFF	53.
OFF	OFF	ON	ON	OFF	ON	OFF	ON	54.
OFF	OFF	ON	ON	OFF	ON	ON	OFF	55.
OFF	OFF	ON	ON	OFF	ON	ON	ON	56.
OFF	OFF	ON	ON	ON	OFF	OFF	OFF	57.
OFF	OFF	ON	ON	ON	OFF	OFF	ON	58.
OFF	OFF	ON	ON	ON	OFF	ON	OFF	59.
OFF	OFF	ON	ON	ON	OFF	ON	ON	60.
OFF	OFF	ON	ON	ON	ON	OFF	OFF	61.

OFF	OFF	ON	ON	ON	ON	OFF	ON	62.
OFF	OFF	ON	ON	ON	ON	ON	OFF	63.
OFF	OFF	ON	ON	ON	ON	ON	ON	64.
OFF	ON	OFF	OFF	OFF	OFF	OFF	OFF	65.
OFF	ON	OFF	OFF	OFF	OFF	OFF	ON	66.
OFF	ON	OFF	OFF	OFF	OFF	ON	OFF	67.
OFF	ON	OFF	OFF	OFF	OFF	ON	ON	68.
OFF	ON	OFF	OFF	OFF	ON	OFF	OFF	69.
OFF	ON	OFF	OFF	OFF	ON	OFF	ON	70.
OFF	ON	OFF	OFF	OFF	ON	ON	OFF	71.
OFF	ON	OFF	OFF	OFF	ON	ON	ON	72.
OFF	ON	OFF	OFF	ON	OFF	OFF	OFF	73.
OFF	ON	OFF	OFF	ON	OFF	OFF	ON	74.
OFF	ON	OFF	OFF	ON	OFF	ON	OFF	75.
OFF	ON	OFF	OFF	ON	OFF	ON	ON	76.
OFF	ON	OFF	OFF	ON	ON	OFF	OFF	77.
OFF	ON	OFF	OFF	ON	ON	OFF	ON	78.
OFF	ON	OFF	OFF	ON	ON	ON	OFF	79.
OFF	ON	OFF	OFF	ON	ON	ON	ON	80.
OFF	ON	OFF	ON	OFF	OFF	OFF	OFF	81.
OFF	ON	OFF	ON	OFF	OFF	OFF	ON	82.
OFF	ON	OFF	ON	OFF	OFF	ON	OFF	83.
OFF	ON	OFF	ON	OFF	OFF	ON	ON	84.
OFF	ON	OFF	ON	OFF	ON	OFF	OFF	85.
OFF	ON	OFF	ON	OFF	ON	OFF	ON	86.
OFF	ON	OFF	ON	OFF	ON	ON	OFF	87.
OFF	ON	OFF	ON	OFF	ON	ON	ON	88.
OFF	ON	OFF	ON	ON	OFF	OFF	OFF	89.
OFF	ON	OFF	ON	ON	OFF	OFF	ON	90.
OFF	ON	OFF	ON	ON	OFF	ON	OFF	91.
OFF	ON	OFF	ON	ON	OFF	ON	ON	92.
OFF	ON	OFF	ON	ON	ON	OFF	OFF	93.
OFF	ON	OFF	ON	ON	ON	OFF	ON	94.
OFF	ON	OFF	ON	ON	ON	ON	OFF	95.
OFF	ON	OFF	ON	ON	ON	ON	ON	96.
OFF	ON	ON	OFF	OFF	OFF	OFF	OFF	97.
OFF	ON	ON	OFF	OFF	OFF	OFF	ON	98.
OFF	ON	ON	OFF	OFF	OFF	ON	OFF	99.
OFF	ON	ON	OFF	OFF	OFF	ON	ON	100.
OFF	ON	ON	OFF	OFF	ON	OFF	OFF	101.
OFF	ON	ON	OFF	OFF	ON	OFF	ON	102.
OFF	ON	ON	OFF	OFF	ON	ON	OFF	103.
OFF	ON	ON	OFF	OFF	ON	ON	ON	104.
OFF	ON	ON	OFF	ON	OFF	OFF	OFF	105.
OFF	ON	ON	OFF	ON	OFF	ON	ON	106.
OFF	ON	ON	OFF	ON	OFF	ON	OFF	107.
OFF	ON	ON	OFF	ON	OFF	ON	ON	108.
OFF	ON	ON	OFF	ON	ON	OFF	OFF	109.
OFF	ON	ON	OFF	ON	ON	OFF	ON	110.
OFF	ON	ON	OFF	ON	ON	ON	OFF	111.
OFF	ON	ON	OFF	ON	ON	ON	ON	112.
OFF	ON	ON	ON	OFF	OFF	OFF	OFF	113.
OFF	ON	ON	ON	OFF	OFF	OFF	ON	114.
OFF	ON	ON	ON	OFF	OFF	ON	OFF	115.
OFF	ON	ON	ON	OFF	OFF	ON	ON	116.
OFF	ON	ON	ON	OFF	ON	OFF	OFF	117.
OFF	ON	ON	ON	OFF	ON	OFF	ON	118.
OFF	ON	ON	ON	OFF	ON	ON	OFF	119.
OFF	ON	ON	ON	OFF	ON	ON	ON	120.
OFF	ON	ON	ON	ON	OFF	OFF	OFF	121.
OFF	ON	ON	ON	ON	OFF	OFF	ON	122.
OFF	ON	ON	ON	ON	OFF	ON	OFF	123.
OFF	ON	ON	ON	ON	OFF	ON	ON	124.
OFF	ON	ON	ON	ON	ON	OFF	OFF	125.
OFF	ON	ON	ON	ON	ON	ON	ON	126.
OFF	ON	ON	ON	ON	ON	ON	OFF	127.
OFF	ON	ON	ON	ON	ON	ON	ON	128.

SW4 (1 - 6) Output Protocol & Baud Selection for **V36** software

PROTOCOL	BAUD	1	2	3	4	5	6	PAGE
1.SELF TEST	9600 N 8 1	off	off	off	Off	off	off	-
2.DEBUG MODE	19200 N 8 1	ON	off	off	Off	off	off	11
3.360 VISION	9600 N 8 1	off	ON	ON	ON	ON	off	14
4.BBV RS485	9600 N 8 1	ON	ON	ON	Off	off	off	-
5.BBV RX450/RX550	9600 N 8 1	ON	off	off	ON	off	off	-
6.CHUGAI SMD20	9600 N 8 1	ON	ON	ON	ON	ON	off	15
7.CHUGAI ZC- S122	9600 E 8 1	off	ON	off	ON	off	off	16
8.CONWAY	9600 N 8 1	off	ON	off	ON	off	ON	17
9.COP DOME (PELCO P/D)	2400/9600 N 8 1	off	ON	ON	off	off	ON	18
10.DENNARD 20xx series	9600 N 8 1	off	ON	off	Off	off	off	18
11. DM DTMF via TAD3 (Camera select sent every command)	9600 N 8 1	ON	off	ON	ON	off	ON	19
12. DM DTMF via TAD3 (Camera select only sent if camera number changed)	9600 N 8 1	off	ON	ON	ON	off	ON	19
13.FORWARD VISION	9600 O 8 1	ON	ON	ON	off	off	ON	20
14.JVC TK-C676	9600 E 8 1	off	off	off	ON	off	off	22
15.LG DOME (PELCO D) LPT-OI551HQ/OI553HQ	9600 N 8 1	ON	off	off	ON	off	ON	22
16.MARK MERCER	9600 N 8 1	ON	ON	off	Off	off	off	23
17.MEYERTECH VICTA	9600 N 8 1	ON	ON	off	off	off	ON	24
18.MOLYNX	9600 E 8 1	ON	ON	off	ON	off	off	25
19. NIO/DYNAPEL INTERCEPTER (Pelco D)	9600 N 8 1	off	off	off	off	ON	ON	26
20.PANASONIC 850	9600 N 8 1	ON	off	ON	Off	off	off	27
21.PANASONIC 850	19200 N 8 1	off	ON	ON	Off	off	off	
22.	9600 N 8 1	off	off	ON	ON	off	off	28
23.	9600 O 8 1	ON	off	ON	ON	off	off	
24.	9600 E 8 1	off	ON	ON	ON	off	off	
25.	4800 N 8 1	ON	ON	ON	ON	off	off	
26. PELCO P	4800 O 8 1	off	off	off	Off	ON	off	
27.	4800 E 8 1	ON	off	off	Off	ON	off	
28.	2400 N 8 1	off	ON	off	Off	ON	off	
29.	2400 O 8 1	ON	ON	off	Off	ON	off	
30.	2400 E 8 1	off	off	ON	Off	ON	off	
31.	9600 N 8 1	ON	off	ON	off	ON	off	
32.	9600 O 8 1	off	ON	ON	off	ON	off	
33.	9600 E 8 1	ON	ON	ON	off	ON	off	
34.	4800 N 8 1	off	off	off	ON	ON	off	
35. PELCO D	4800 O 8 1	ON	off	off	ON	ON	off	
36.	4800 E 8 1	off	ON	off	ON	ON	off	
37.	2400 N 8 1	ON	ON	off	ON	ON	off	
38.	2400 O 8 1	off	off	ON	ON	ON	off	
39.	2400 E 8 1	ON	off	ON	ON	ON	off	
40.PHILIPS RS232	9600 N 8 1	off	off	ON	off	off	ON	29
41.PHOTOSCAN	2400 E 8 1	off	off	off	ON	off	ON	30

42.SAMSUNG SCC641/643	9600 N 8 1	off	ON	off	off	off	ON	31
43.SENSORMATIC RS422	4800 N 8 1	ON	off	ON	off	off	ON	32
44.VCL	9600 N 8 1	off	off	ON	Off	off	off	34
45.VICON	4800/9600 N 8 1	off	off	off	off	off	ON	35
47.VIDECON VCP451	2400 N 8 1	off	off	ON	ON	off	ON	36
46.VIDECON VHSD860	9600 N 8 1	ON	ON	off	ON	off	ON	37
48.Videotec Ulisse(Pelco D)	9600 N 8 1	ON	ON	ON	ON	off	ON	38
49.VISTA POWERDOME	9600 N 8 1	ON	off	off	off	off	ON	39

FORMAT OF BAUD SETTINGS, BAUD RATE PARITY (NONE, EVEN, ODD) DATABITS STOPBITS

STOP AND READ BEFORE INSTALLING!

AS 3RD PARTY PROTOCOLS ARE NOT UNDER THE CONTROL OF BBV, WE CANNOT GUARANTEE THAT THIS UNIT WILL PROVIDE THE EXACT FUNCTIONALITY REQUIRED.

IT IS STRONGLY RECOMMENDED THAT OPERATION IS CONFIRMED DURING PRE BUILD TESTING BEFORE INSTALLING ON SITE.

PLEASE CONTACT OUR CUSTOMER SUPPORT DEPARTMENT IF YOU HAVE ANY QUESTIONS/ISSUES:

Tel: ++ 44 (0) 1323 444600

Email: support@bbvcctv.com

RS232 serial port

The DB9F connector provides the ability to use a laptop PC to monitor the data being sent out of the 1-2-1 converter via RS232.

On power up or if SW2, SW3 or SW4 switches are altered the unit sends the current protocol, baud rate and parity settings. Please be aware that the laptop baud rate and parity must match the settings selected with SW4. If the settings do not match then the laptop display will have no meaning.

A power up message example is shown below:

```
BBV 1-2-1 converter conv3V36
www.bbvctv.com
SW2(ADDR) = 01
SW3(IN) = 10 BBV:9600,N,8,1
SW4(OUT) = A3 MARK MERCER V7.3:9600,N,8,1
```

A debug mode can also be selected which provides detailed information for each command received. Whilst trouble shooting BBV engineers may ask you to use this mode with a laptop or other PC:

```
BBV 1-2-1 converter conv3V36
www.bbvctv.com
SW2(ADDR) = 01
SW3(IN) = 10 BBV:9600,N,8,1
SW4 (OUT) = 01 DEBUG MODE:19200,N,8,1
```

```
CAM=00 W3=00 W4=14 W5=40 W6=24 PL 064TD 036
CAM=00 W3=00 W4=14 W5=06 W6=3C PL 006TD 060
CAM=00 W3=00 W4=12 W5=2E W6=38 PR 046TD 056
CAM=00 W3=00 W4=12 W5=40 W6=08 PR 064TD 008
CAM=00 W3=00 W4=08 W5=00 W6=0C TU 012
CAM=00 W3=00 W4=04 W5=40 W6=00 PL 064
CAM=00 W3=00 W4=14 W5=32 W6=34 PL 050TD 052
CAM=00 W3=00 W4=12 W5=2A W6=38 PR 042TD 056
CAM=00 W3=00 W4=04 W5=36 W6=00 PL 054
CAM=00 W3=00 W4=00 W5=00 W6=00 Cam 00 stop
```

The example above shows the debug output for Camera 1. Driving pan/tilt followed by a stop command.

The following table shows the possible input and output protocols that are supported with this version of software.

Output Protocol	Input Protocol					Page
	BBV TX1500/FBM	PELCO D/P	VCL	360 VISION	VICON	
360 VISION	X		X			13
BBV RS485 (RX45X/55X)	X	X				-
BBV RX450/550	X	X				-
Chugai SMD20	X					15
Chugai ZCS122/123	X					16
CONWAY DOME	X					17
COP (PELCO D)	X					18
DENNARD 2050	X	X				18
DM DTMF(VIA TAD3)	X					19
FORWARD VISION	X					20-21
JVC TKC676	X	X				22
LG DOME (PELCO D)	X					22
MARK MERCER	X	X			X	23
MEYERTECH VICTA	X					24
MOLYNX 250/260	X	X				25
NIO D86 INTERCEPTER	X					26
PANASONIC CS850/860	X					27
PELCO D/P	X	X				28
PHILIPS RS232	X					29
PHOTOSCAN Single camera at a time!	X					30
SAMSUNG SCC641/643	X					31
SENSORMATIC RS422	X					32
VCL TP	X	X		X		33 -34
VICON	X					34
VIDECON VCP451	X					36
VIDECON VHSD 860	X					37
VIDEOTECH ULISSE	X					38
VISTA POWERDOME	X					39

Protocol specific information

SW4

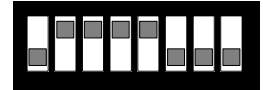

360 VISION from BBV telemetry

Connect dome D+ to 1-2-1 converter TA and dome D- to 1-2-1 converter TB.

Set the dome address using the DIL switch to match the number of the camera input of the TX1500.

Ensure that the dome at the end of a daisy chained RS485 run has the RS485 terminated and the intermediate domes have the RS485 de-terminated.

The following functionality is provided:

Manual pan/tilt control with 16 speed steps from 1 to 127, (slowest to fastest)

Zoom with Manual Iris and Focus override.

Operating the Zoom will re-enable auto focus and iris after manual adjustment

32 preset positions.

2 sequential preset tours of preset positions 1 - 16, tour 1 high speed and tour 2 slow speed. The dwell time is fixed at 10 seconds per preset position. Preset positions can be removed from the tours.

All 32 privacy zones can be programmed and disabled if required.

Advanced Function	TX1500 Procedure
180 degree pan flip (U turn)	1 #
Program a privacy zone	2 # followed by PROGRAM 1-32 PRESET
Clear a privacy zone	3 # followed by PROGRAM 1-32 PRESET
Add preset position to the tours	Programming a preset position adds the preset into the tour. (1 – 16 only)
Remove a preset from the tours	PROGRAM 50 PRESET followed by 1-16 PRESET
Start preset tour 1 – high speed	1 PATROL (max speed with 10 second dwell)
Start preset tour 2 – slow speed	2 PATROL (speed 32 with 10 second dwell)
Set autoflip mode	PROGRAM 51 PRESET followed by 1 PRESET = autoflip OFF 2 PRESET = ON tilt at down limit 3 PRESET = ON when at limit
Set Video Gain/Lift and Sync timing	PROGRAM 52 PRESET followed by IRIS CLOSE/OPEN to increase/decrease GAIN FOCUS NEAR/FAR to increase/decrease LIFT ZOOM IN/OUT to advance/retard timing Move joystick when finished.
Set IR Filter mode	PROGRAM 53 PRESET followed by 1 PRESET = mono mode/auto off 2 PRESET = colour mode/auto off 3 PRESET = auto/kill colour 4 PRESET = auto/don't kill colour
Set Home functions (Revised in V16 software)	PROGRAM 54 PRESET followed by 1-5 PRESET = Function (1=enable,2=disable,3=preset 1,4=tour1,5=mimic 1) 1-60 PRESET = timeout in minutes
Unit Reset. This simulates powering the dome off/on	PROGRAM 55 PRESET followed by PROGRAM 55 PRESET
Preset Tour Definition Example to program tour 1 Step 1 – define tour. PROGRAM 56 PRESET Step 2 – tour 1 or 2. 1 PRESET Step 3 – 4 presets for each preset point 1 PRESET (point 1) 1 PRESET (PRESET 1) 64 PRESET (max speed) 10 PRESET (10 seconds dwell)	PROGRAM 56 PRESET (start definition) 1 or 2 PRESET – Tour number 1 – 64 PRESET (tour point number) 1 – 32 PRESET (preset number) 1 – 64 PRESET (speed) 1 – 64 PRESET (dwell in seconds)

Repeat step 3 for each point until the last point Step 4 – last tour point. PROGRAM 57 PRESET 3 PRESET (point 3) 4 PRESET (PRESET 4) 32 PRESET (middle speed) 2 PRESET (2 seconds dwell)	repeated for each point apart from last PROGRAM 57 PRESET (last point) 1 – 64 PRESET (tour point number) 1 – 32 PRESET (preset number) 1 – 64 PRESET (speed) 1 – 64 PRESET (dwell in seconds)
The tour is now defined	
Mimic Tour Definition (AUTOPAN will replay the mimic tour)	PROGRAM 58 PRESET (start definition) Use joystick and zoon to move dome around required tour. PROGRAM 59 PRESET (end definition)
Fast Shutter ON (ANPR mode)	PROGRAM 60 PRESET
Fast Shutter OFF (normal mode)	PROGRAM 61 PRESET

360 VISION from VCL telemetry

SW3

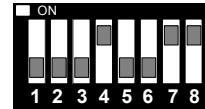

SW4

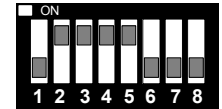

Connect dome D+ to 1-2-1 Converter TA and dome D- to 1-2-1 Converter TB.

Set the dome address using the DIL switch to match the number of the camera input of the TX1500. Ensure that the dome at the end of a daisy chained RS485 run has the RS485 terminated and the intermediate domes have the RS485 de-terminated.

The following functionality is provided:

Manual pan/tilt control with 16 speed steps from 1 to 127 (slowest to fastest)

Zoom with Manual Iris and Focus override.

Operating the Zoom will re-enable auto focus and iris after manual adjustment

32 preset positions.

Preset 100 – 127 will program the dome privacy zone 1 – 27. These can be disabled within the VCL privacy menu by setting the appropriate preset to PRESET. The dome will move to show the privacy scene to allow toggling the privacy back on by selecting PRIVATE.

Tour definitions are compatible with the VCL programming method 2 including dwell time and speed per tour point.

The dome home feature can be programmed using the standard VCL control menu.

In addition to the standard functions offered by the VCL control system the following features are available:

Set autoflip mode	program preset 51 followed by goto preset 1 = autoflip OFF goto preset 2 = ON tilt at down limit goto preset 3 = ON when at limit
Set Video Gain/Lift and Sync timing	program preset 52 followed by iris close/open to increase/decrease GAIN focus near/far to increase/decrease LIFT zoom in/out to advance/retard timing Move joystick when finished.
Set IR Filter mode	program preset 53 followed by goto preset 1 = mono mode/auto off goto preset 2 = colour mode/auto off goto preset 3 = auto/kill colour goto preset 4 = auto/don't kill colour
Set Home functions (fixed at 5 minutes)	program preset 54 followed by goto preset 1 = Enable to preset 1 goto preset 2 = Enable to patrol 1 (fast) goto preset 3 = Enable to patrol 2 (slow) goto preset 4 = Disable home
Unit Reset. This simulates powering the dome off/on	program preset 55 twice

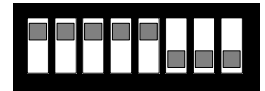

Connect dome DATA+ to Converter TA and dome DATA- to Converter TB.
Set the dome address using the DIL switch to match the number of the camera input of the TX1500.

Ensure that the dome at the end of a daisy chained RS485 run has the RS485 terminated and the intermediate domes have the RS485 de-terminated.

This type of dome can be addressed from 1 – 31. To allow use of more than 31 domes on a TX1500 system the 1-2-1 converter can be adjusted to select banks of cameras as follows:

Camera Range	SW4/7	SW4/8
1 - 31	OFF	OFF (Default setting)
32 - 62	ON	OFF
63 - 93	OFF	ON
94 - 124	ON	ON

When the 1-2-1 converter is set for camera range 32 – 62, the dome connected into video input 32 must have the address set for 1 and video input 33 must have the address set to 2 etc up to video input 62 with the address set to 31.

i) Timing to the dome is critical, due to the nature of the dome protocol (half duplex command and response commands). The dome will ignore any command sent before it has finished executing the previous command; for example, a goto preset command sent whilst the dome is searching for another preset, (e.g. multiple alarm occurrences in quick succession).

ii) Supported manual PTZ with manual focus which reverts back to auto focus on a pan/tilt or zoom.

iii) 64 preset positions are supported

iv) The AUTOPAN key is used to start patrol 2.

v) 2 preset patrols are provided and the preset positions in each patrol are programmable. Patrol 1 has a fixed full speed movement to each preset and a dwell of 10 seconds. To define patrol 1, first PROGRAM 65 PRESET, followed by GOTO preset for each of the presets to be patrolled. Up to 64 presets can be programmed. Each preset position must be programmed prior to defining the patrol. To end the definition PROGRAM 66 PRESET.

Patrol 2 has a fixed slow speed movement between preset positions and a 10 second dwell at each position. Programming is similar to Patrol 1. PROGRAM 67 PRESET to start definition, goto preset ... followed by PROGRAM 68 PRESET to end the definition. Patrol 2 can also be started by pressing the AUTOPAN key.

vi) LEDS, LD2 flashes when commands are received for domes that lie outside of the 31 camera range set by SW2, SW4/7 and SW4/8.

IMPORTANT: THE DOME WILL IGNORE ALL COMMANDS SENT FROM THE 1-2-1 CONVERTER WHEN IT IS MOVING TO A PRESET POSITION UNTIL THE PRESET POSITION HAS BEEN REACHED. THIS RELATES TO MANUAL PRESET OR DURING A PATROL.

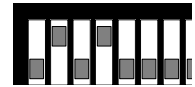

Function	TX1500 Procedure
Menu ON/OFF	1 #
SET (whilst in menu)	2 #
CLR (whilst in menu)	3 #
PRESET SEQUENCE	1 PATROL
PLAYBACK TRACE	2 PATROL
AUTOPAN	AUTOPAN
AUX 1 OUTPUT ON/OFF	LIGHTS
AUX 2 OUTPUT ON/OFF	WIPER

Notes:

Connect dome A/+ (pin 1, BROWN) to the 1-2-1 converter TA and dome B/- to the 1-2-1 converter TB. Each dome must be set to 9600 Baud with switch 5 OFF, switch 6 ON. Set the dome address using the dome rotary switches to match the number of the camera input of the TX1500. Ensure that domes at the end of the RS485 run are terminated by turning switch 8 ON and the intermediate domes have the switch 8 OFF.

A total of up to 96 domes are supported with a maximum of 32 domes per star output.

Menu access:

Press 1# will toggle the Menu display ON/OFF.
 Whilst the menu is displayed the joystick is used to navigate.
 2# is used as SET to access a menu option and
 3# is used as CLR to go back.

Addition functions are available for the currently displayed dome:

AUTOPAN is started by pressing the AUTOPAN key.
 PRESET SEQUENCE is started by pressing 1 PATROL.
 TRACE playback is started by preceding 2 PATROL

The protocol 1-2-1 converter can directly access preset 1 – 64 by pressing the preset number followed by the PRESET key.

To program a preset position, press PROGRAM followed by the preset number and the PRESET key. See the TX1500 manual for detailed information.

CONWAY dome from BBV telemetry only

Connect the twisted pair as follows:

Dome A to 1-2-1 converter TB

Dome B to 1-2-1 converter TA

SW4

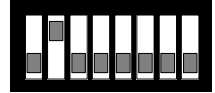

The following functionality is provided:

Variable speed Pan/Tilt

Zoom/Focus/Iris

64 preset positions

Preset tour 1 & 2 playback only

Wash/WIPE/LIGHTS (IR Filter ON/OFF)

Privacy enable, disable

Additional dome features

Dome Function	TX1000 Keystroke	TX1500 Keystroke
ENABLE PRIVACY	hold # and tap WIPE	2 #
DISABLE PRIVACY	hold # and tap AUTOPAN	3 #
TOUR 1 PLAYBACK	hold PATROL and tap 1	1 PATROL
TOUR 2 PLAYBACK	hold PATROL and tap 2	2 PATROL
IR CUT FILTER ON/OFF	LIGHTS ON/OFF	LIGHTS ON/OFF

Note:

The Data connections A/B are crossed when using this dome so please connect the dome A to green connector TB and dome B to green connector TA.

Preset tours programming is NOT supported. These must be defined first using a CONWAY controller.

For more information please refer to the dome handbook.

COP PELCO D or PELCO P from BBV telemetry only

Connect the twisted pair as follows:
dome RS485+ (ORANGE) to 1-2-1 converter TA
dome RS485- (YELLOW) to 1-2-1 converter TB

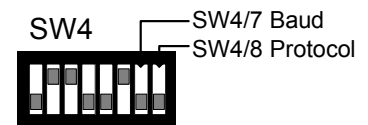

Baud Rate	SW4/7
2400	OFF (default)
9600	ON
Protocol	SW4/8
PELCO D	OFF (default)
PELCO P	ON

Set the dome for protocol and baud rate. The default is 2400 baud and Pelco D telemetry.
Set the dome address to match the number of the camera input of the matrix.

The following functionality is provided:

- Variable speed Pan/Tilt
- Zoom/Focus/Iris
- 63 preset positions.
- Menu access and navigation
- Pattern record and playback
- Preset patrol 1 and 2 playback

Additional Dome features

Dome Function	TX1000 Keystroke	TX1500 Keystroke
DISPLAY DOME MENU	hold # and tap WASH and navigate using the joystick and IRIS keys	1 # and navigate using the joystick and IRIS keys
PATTERN RECORD START	hold # and tap AUTOPAN then use joystick to move dome around required scenes.	3 # then use joystick to move dome around the required scenes.
PATTERN RECORD STOP	hold # and tap LIGHTS	4 #
PATTERN PLAYBACK	AUTOPAN	AUTOPAN
PATROL 1 PLAYBACK	hold PATROL and tap 1	1 PATROL
PATROL 2 PLAYBACK	hold PATROL and tap 2	2 PATROL

DENNARD 20xx – Fixed at 9600,N,8,1 (adjust SW3 to suit input protocol)

SW4



Connect the twisted pair as follows:
dome RS485+ (YELLOW) to 1-2-1 converter TA
dome RS485- (GREEN) to 1-2-1 converter TB

Function	TX1500 Procedure	Pelco Procedure
Display Dome Menu	1 #	SAVE PRESET 95
Display User Menu	2 #	GOTO PRESET 33
Display Technicians Menu	3 #	GOTO PRESET 94
Start current dome's Sequence 001	1 PATROL	GOTO PRESET 97
Start ALL DOMES Sequence 001	2 PATROL	GOTO PRESET 98

Navigate through the dome menu using pan/tilt and issue GOTO PRESET 1 to select current line.

FORWARD VISION MIC-1300/400 from BBV telemetry only

SW4



Connect the twisted pair as follows:

Dome RX A (YELLOW) to 1-2-1 converter TB (A & B swapped)

Dome RX B (WHITE) to 1-2-1 converter TA

Set the dome address to match the number of the camera input of the matrix.

The following functionality is provided:

Variable speed Pan/Tilt

Zoom/Focus/Iris

64 preset positions.

Patrol (sequence) record. 8 positions of presets 1 – 16

Autopan

Additional dome features

Dome Function	TX1000 Keystroke	TX1500 Keystroke
SPECIAL PROGRAMMING (see below)	hold # and tap WASH	1 #
DIGITAL ZOOM ON/OFF	hold # and tap WIPE	2 #.
MANUAL/AUTO EXPOSURE	hold # and tap AUTOPAN	3 #
IR FILTER IN/OUT	hold # and tap LIGHTS	4 #
ENABLE ALL SCENE	Hold # and tap WASH, PROGRAM 1, 1	1 # PROGRAM 1 PRESET
DISABLE ALL SCENE	Hold # and tap WASH, PROGRAM 1, 2	1 # PROGRAM 2 PRESET
TOGGLE CURSOR ON/OFF	Hold # and tap WASH, PROGRAM 1, 3	1 # PROGRAM 3 PRESET
ENABLE AROUND CURSOR	Hold # and tap WASH, PROGRAM 1, 4	1 # PROGRAM 4 PRESET
DISABLE AROUND CURSOR	Hold # and tap WASH, PROGRAM 1, 5	1 # PROGRAM 5 PRESET

PROGRAM PRESET PATROL

The 1-2-1 CONVERTER supports a single preset patrol per dome with a programmable dwell time and up to 8 preset positions. Please ensure that you program the preset positions first using the normal procedure. The keystrokes used will depend on the controller used. The TX1000 and TX1500 procedures are shown below.

TX1000

- a. Hold # and tap **WASH**, then Hold **PATROL** and tap **1** (patrol programming mode)
- b. Hold **PRESET** and tap **1 – 16** (dwell time 1 – 16 seconds)
- c. Hold **PRESET** and tap **1 – 16** (first preset position)
- d. repeat step C for up to 8 preset positions total
- e. Hold **PATROL** and tap **1** (save the dome patrol)

TX1500

- a. **1 #** then **1 PATROL** (patrol programming mode)
- b. **1 – 64 PRESET** (dwell time 1 – 64 seconds)
- c. **1 – 64 PRESET** (first preset position)
- d. repeat step C for up to 8 preset positions in total
- e. **1 PATROL** (save the dome patrol)

Continued on page 21

In addition, the following dome features are supported. First either 1# from TX1500 or Hold # and tap WASH then program the following presets:

FUNCTION	PROGRAM PRESET
PAN REVERSE ON/OFF (PRESET 194/195)	6 ON, 7 OFF
AUTO IR ON/OFF (PRESET 196/197)	8 ON, 9 OFF
INTERMITANT WIPE ON/OFF (PRESET 198/199)	10 ON, 11 OFF
SOFTLIMIT TOP LEFT (PRESET 200)	12
SOFTLIMIT BOTTOM RIGHT (PRESET 201)	13
NONE DWELL TOP LEFT (PRESET 202)	14
NONE DWELL BOTTOM RIGHT (PRESET 203)	15
AUTOHOME PRESET 1 (PRESET 204)	16
AUTOHOME SEQUENCE (PATROL) (PRESET 205)	17
AUTOHOME OFF (PRESET 206)	18
MULTI ALARM ON/OFF (PRESET 207/208)	19 ON, 20 OFF
DIGITAL ZOOM ENABLE/DISABLE (PRESET 209/210)	21 ON, 22 OFF
SET TOUR1,2,3,4,5,6 (PRESET 211-216)	23 – 28
AUTOFLIP ON/OFF (PRESET 217/218)	29 ON, 30 OFF
WASHWIPE ON/OFF (PRESET 219/220)	31 ON, 32 OFF
PRIVACY SET CURSOR (PRESET 221)	33
PRIVACY INIT PARAMETER (PRESET 222)	34
PRIVACY LOAD PARAMETER (PRESET 223)	35
PRIVACY SAVE PARAMETER (PRESET 224)	36
PRIVACY HIDE CURSOR (PRESET 225)	37
PRIVACY SHOW CURSOR (PRESET 226)	38
PRIVACY CLEAR CENTRAL (PRESET 227)	39
PRIVACY SET CENTRAL (PRESET 228)	40
PRIVACY SET STYLE (PRESET 229)	41
PRIVACY HIDE STYLE (PRESET 230)	42
PRIVACY SHOW STYLE (PRESET 231)	43
PRIVACY REPLACE ALL (PRESET 232)	44
PRIVACY UNCOVER ALL (PRESET 233)	45
PRIVACY CLEAR WHOLE (PRESET 234)	46
PRIVACY SET WHOLE (PRESET 235)	47
AUTO ALARM ON/OFF (PRESET 236/237)	48 ON, 49 OFF
AUTO LOWLIGHT ON/OFF (PRESET 238/239)	50 ON, 51 OFF)
CAMERA RECALIBRATE (PRESET 251)	52
RESET PRESETS (PRESET 255)	53

As the TX1000 supports up to preset 16 all commands that require preset 17 and higher can't be accessed. A TX1500 must be used in this case.

For example to enable auto IR use the following keystrokes

TX1000

Hold # and tap WASH (extended dome command mode)

PROGRAM 1 then 8 (program preset 8)

TX1500

1 # (extended dome command mode)

PROGRAM 8 PRESET (program preset 8)

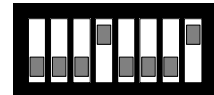

Function	TX1500 Procedure	Pelco Procedure
Display menu and EXIT	1 #	SAVE PRESET 95
SET (whilst in menu)	2 #	GOTO PRESET 33
Toggle Extended Dynamic Range	3 #	GOTO PRESET 94
Cycle BW mode, ON/OFF/AUTO	4 #	
Start dome AUTO PATROL	1 PATROL	GOTO PRESET 97
As above for ALL DOMES	2 PATROL	GOTO PRESET 98
Start dome AUTOPAN	AUTOPAN	GOTO PRESET 99
Force AUTOFOCUS after zoom	SW4/7 ON will force the dome to AUTOFOCUS after a zoom stop command. This is useful when used with 675BE domes.	

Notes:

Connect dome RX- to the 1-2-1 converter TB and dome RX+ to the 1-2-1 converter TA.

Each dome must be set to Multi-drop, Simplex mode by setting dome switch 4 & 5 ON. Set each dome address using the dome rotary switches. This address must match the number of the camera input of the telemetry controller.

To display the current dome's menu, press either 1# with the BBV TX1500 or SAVE PRESET 95 using Pelco-P or Pelco-D protocol. Use standard PAN/TILT and where required ZOOM to navigate through the menus. To simulate the SET key to navigate into sub-menus press 2# with a TX1500 or GOTO PRESET 33 when using Pelco protocols. To exit the current menu press 1# for the TX1500 or SAVE PRESET 95 with Pelco.

Addition functions.

Pressing AUTOPAN with a TX1500 or GOTO PRESET 99 with Pelco will cause the current dome to start an AUTOPAN.

Pressing 1 PATROL with a TX1500 or GOTO PRESET 97 with Pelco will cause the current dome to start an AUTOPATROL.

Pressing 2 PATROL with a TX1500 or GOTO PRESET 98 with Pelco will cause ALL the domes to start an AUTOPATROL.

Extended Dynamic Range can be toggled ON/OFF using 3# with the TX1500 or GOTO PRESET 94 with Pelco.

B/W Mode can be cycled between ON/OFF/AUTO using 4# with the TX1500.

Camera mode display. Protocol 1-2-1 converter SW4/8

If protocol 1-2-1 converter switch SW4/8 is set to ON then each time the Extended Dynamic Range or BW mode is changed or AUTOPATROL is selected then the dome title is altered to display these settings. If it is preferred to use the dome camera title for titling then set switch SW4/8 OFF. The settings will still be changed but will not be shown.

Presets

The dome home preset position is preset 0. As most control systems do not directly support preset 0, preset 1 is used instead. This means that in practice, preset 1 is home, preset 2-32 are preset 2-32 and the dome's preset 1 is not used. This could only be an issue when programming alarms directly into the dome. Do not use preset position 1 unless this is programmed from within the dome menu.

LG DOME (PELCO D) from BBV telemetry only.

SW4



Connect the twisted pair as follows:
 Dome TRX D+ (RED) to 1-2-1 converter TA
 Dome TRX D- (GREEN) to 1-2-1 converter TB

Dome SW301 – 1 OFF, 2 ON, 3 ON, 4 OFF (Selects Pelco D)
 Dome SW304 – ALL OFF (9600 baud)
 Dome SW302 – Address – set to match the matrix camera input

The following functionality is provided:
 Variable speed Pan/Tilt
 Zoom/Focus/Iris
 64 preset positions
 Menu access and navigation
 Pattern record and playback
 Preset patrol 1

Additional Dome features

Dome Function	TX1000 Keystroke	TX1500 Keystroke
DISPLAY DOME MENU	hold # and tap WASH and navigate using the ZOOM and FOCUS keys	1 # and navigate using the ZOOM and FOCUS keys
180 DEGREE PAN FLIP	hold # and tap WIPE	2 #
PATTERN RECORD START	hold # and tap AUTOPAN then use joystick to move dome around required scenes.	3 # then use joystick to move dome around the required scenes.
PATTERN RECORD STOP	hold # and tap LIGHTS	4 #
PATTERN PLAYBACK	AUTOPAN	AUTOPAN
PATROL 1 PLAYBACK	hold PATROL and tap 1	1 PATROL

Note:

When navigating the dome menu ZOOM IN moves the cursor UP and ZOOM OUT moved the cursor DOWN. The FOCUS keys are used to ENTER and change values.

For more information please refer to the dome handbook.

SW3



SW4



MARK MERCER from from BBV telemetry

Function	TX1500 Procedure	Pelco Procedure
180 Pan U turn	1 # or WASH	SAVE PRESET 95
Start current dome's patrol	1 PATROL	GOTO PRESET 97
Start ALL DOMES patrol	2 PATROL	GOTO PRESET 98

SW3



SW4



MARK MERCER from VICON

When used with VICON protocol the Mark Mercer protocols supports 79 preset positions. Preset 80-89 will cause the dome preset patrol 1 to start. The patrol cannot be changed once preset positions have been saved.

The VICON protocol baud rate can be set from 2400, 4800, 9600 and 19200 using SW3/4 and SW3/5 as the previous diagram.

Meyertech ZVR-510 receiver with VICTA protocol from BBV telemetry only.

Connect receiver 422 RX+ to 1-2-1 converter TA and 422 RX- to 1-2-1 converter TB.
Set the receiver address to match the number of the camera input of the matrix.

The following functionality is provided.
Variable speed Pan/Tilt – 8 speeds
Zoom/Focus
WASH, WIPE, LIGHTS auxiliary outputs
32 preset positions.
Menu access and navigation

SW4

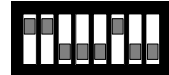

The Meyertech protocol supports 8 speeds for pan and tilt. If the head is to pan and tilt simultaneously then the same speed is used for both axis. For example if the head is moving left at say speed 4 and then the joystick is moved up the head will now move left at the new tilt speed. This is not a problem with the 1-2-1 converter but a limitation of the Meyertech protocol.

Receiver Menu Access and navigation.

Receiver Function	TX1500 Keystroke
RECEIVER MENU ON Once the receiver menu is displayed the joystick is used to navigate the cursor.	1 # (same as PROGRAM 95 PRESET)
MENU ENTER Select the flashing item	2 # (same as 33 PRESET)
MENU TOGGLE ITEM Used to cycle options displayed in [] brackets.	3 # (same as 94 PRESET)
EXIT MENU MODE – ALLOW PTZ This must be sent when the menu has been exited to allow normal pan/tilt control with the joystick.	4 #
ENTER NUMBERS 0 – 9	1 – 9 PRESET = number 1 – 9 10 PRESET = number 0
AUX A1 ON/OFF	GOTO PRESET 81 / GOTO PRESET 82

Molynx protocol – Fixed at 9600,E,8,1 Control from BBV protocol only

SW4



Function	TX1500 Procedure
PRESET 1 – 32	As manual
WASH, WIPE, LIGHTS	As manual
TOGGLE MENU ON/OFF	1 #
TOGGLE JOYSTICK PTZ/MENU CONTROL	2 #
SET IN MENU	IRIS OPEN or 3 #
DEFINE PRESET PATROL	4#
RESET RECEIVER	PROGRAM 99 PRESET

Notes:

Connect receiver + to the 1-2-1 converter TA and receiver - to the 1-2-1 converter TB.
Set the receiver address switches to match the number of the camera input of the matrix.

Molynx receivers can only be controlled when using BBV telemetry into the 1-2-1 converter ie from the BBV TX1500 or FBM series matrix.

Control of the receiver auxiliary relays is possible using the matrix Wash, Wipe and Lights keys.

Up to 32 preset positions can be programmed and recalled.

Dome mono/colour selection is possible using the **LIGHTS** button once the mono/colour switching has been set to MAN in the dome menu.

Preset Patrol Definition.

A single preset patrol can be defined which can contain up to 16 preset positions. The patrol speed and delay can be programmed as a global for each preset position. Use the following keystrokes.

4#

- 1 – 32 PRESET** This is the delay in seconds for all preset positions
- 1 – 32 PRESET** This is the speed to move between preset positions
1 is very slow and 32 is full speed

Next up to 16 preset positions, eg for patrol presets 1, 3, 6 and 17

1 PRESET, 3 PRESET, 6 PRESET, 17 PRESET
MOVE JOYSTICK This ends the definition.

To start the preset patrol press **1 PATROL**

Improvement added in Version 30

SW4/8 can be used to allow the CAMERA POWER Aux to be operated from AUTOPAN allowing AUTOPAN control of AC receivers.

SW4/8 ON = enabled this feature, and SW4/8 OFF = disables

NIO D86/Interceptor (PELCO D) from BBV telemetry only

SW4

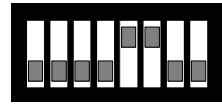

Connect the twisted pair as follows:
dome A+ to 1-2-1 converter TA
dome B- to 1-2-1 converter TB

Dome SW3 – Address, set to match the matrix camera input
Dome SW4 – 1 & 8 ON, 2-7 OFF, Selects PELCO & 9600 BAUD

The following functionality is provided.
Variable speed Pan/Tilt
Zoom/Focus/Iris
64 preset positions.
Menu access and navigation
Pattern record and playback
Tour 1 (preset patrol)
Autoscan (pan between limits)

Additional Dome features

Dome Function	TX1000 Keystroke	TX1500 Keystroke
DISPLAY DOME MENU	hold # and tap WASH and navigate using the joystick and IRIS keys	1 # and navigate using the Joystick and IRIS keys
PATTERN RECORD START	hold # and tap AUTOPAN then use joystick to move dome around required scenes.	3 # then use joystick to move dome around the required scenes.
PATTERN RECORD STOP	hold # and tap LIGHTS	4 #
PATTERN PLAYBACK	AUTOPAN	AUTOPAN
TOUR PLAYBACK	hold PATROL and tap 1	1 PATROL
AUTOSCAN PLAYBACK	hold PATROL and tap 2	2 PATROL

Note:

PATTERN

The dome pan/tilt/zoom will move through a defined movement.

Define the pattern first by **3#**, then move the dome to view the required areas. Once finished **4#** to end the definition. Press **AUTOPAN** to playback the pattern.

TOUR

This is a sequence of preset positions that the dome moves through. The tour is defined from within the dome menu.

AUTOSCAN

The dome will pan continually between two positions that are defined from within the dome menu.

For more information please refer to the dome handbook.

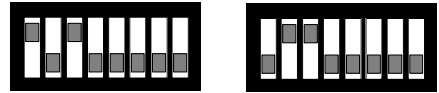

Function	TX1000 Procedure	TX1500 Procedure
Show/Hide dome Menu	# WASH	1 #
ENTER (whilst in menu)	# WIPE	2 #
ESCAPE (whilst in menu)	# AUTOPAN	3 #
SPECIAL2 (whilst in menu)	# LIGHTS	4 #
Send PATROL RUN	PATROL 1	1 PATROL
Send PATROL RUN to ALL DOMES	PATROL 2	2 PATROL
Send AUTOPAN	AUTOPAN	AUTOPAN
BW MODE ON	N/A	89 PRESET
BW MODE OFF	N/A	88 PRESET
BW MODE AUTO	N/A	87 PRESET

Switch and dome settings:

Ensure that each dome is configured BEFORE installation.

Output baud rate must be set to 19200,N,8,1 with SW4.

The dome must be set to Panasonic CONVENTIONAL protocol and the address set accordingly.

The 4 way dome switch must be set to 4 wire telemetry with switches 2,3,4 OFF. The RS485 cable requires termination at the end of the run by setting switch 1 ON.

The Panasonic CS850/860 protocol conversion is only available when controlled using BBV RS485 telemetry. If another input protocol is selected using SW3 then the unit will not function and all the LEDs will flash until BBV protocol is selected again.

Due to protocol issues, the response of an individual dome may become sluggish if several domes are controlled simultaneously.

Connect TA to RA (green) and TB to RB (yellow).

Note:

When working with the TX1000 SW4/8 must be turned ON.

PELCO P and PELCO D

Function	TX1500 Procedure	Pelco Procedure
Display Dome Menu	1 #	SAVE PRESET 95
180 degree pan flip (U turn)	2 #	GOTO PRESET 33
Display Technicians Menu	3 #	GOTO PRESET 94 SW4/8 MUST BE OFF
PATTERN DEFINE (START)	3 #	SW4/8 MUST BE ON
PATTERN DEFINE (STOP)	4 #	SW4/8 MUST BE ON
PATTERN PLAYBACK	AUTOPAN	SW4/8 MUST BE ON
Start Random Scanning	PATROL 1	GOTO PRESET 97
Start Frame Scanning	PATROL 2	GOTO PRESET 98

This allows control of Pelco P and Pelco D units. Please ensure that the baud rate and parity are set correctly. Generally Pelco P uses 9600, N, 8, 1 and Pelco D uses 2400, N, 8, 1.

The Esprit wiper can be controlled using the TX1500 wiper function when SW4/7 is ON. With SW4/7 OFF the LIGHTS button is used. This is due to functions for each auxiliary number.

Function	Aux number SW4/7 ON	SW4/7 OFF
WASH	3	3
WIPE	1	2
LIGHTS	2	1

Additional of zone definition to allow zone blanking of Esprit PTZ heads.

Three steps are required to define and enable privacy zones.

1. Move the camera to the left edge of required privacy zone then program preset 71 – 78. 71 for zone 1, 72 for zone 2 etc up to 78 for zone 8.
2. Now move the camera to the right edge of required privacy zone the program preset 81 – 88. 81 for zone 1, 82 for 2 etc up to 88 for zone 8
3. Next display the head menu and enable zone blanking for the required zone.

Philips RS232/485 from BBV telemetry only (bi-phase via LTC8780/50)

SW4



Depending on the exact model type, Philips domes can be controlled using RS232 or RS485 and bi-phase telemetry.

Bi-phase telemetry is a proprietary twisted pair protocol that allows several domes to be daisy chained. A Philips LTC8780/50 1-2-1 converter is required in addition to the 1-2-1 converter when driving bi-phase telemetry.

Later domes with RS485 inputs can be driven directly from the 1-2-1 converter outputs without the need for a Philips LTC8780/50 1-2-1 converter as shown below.

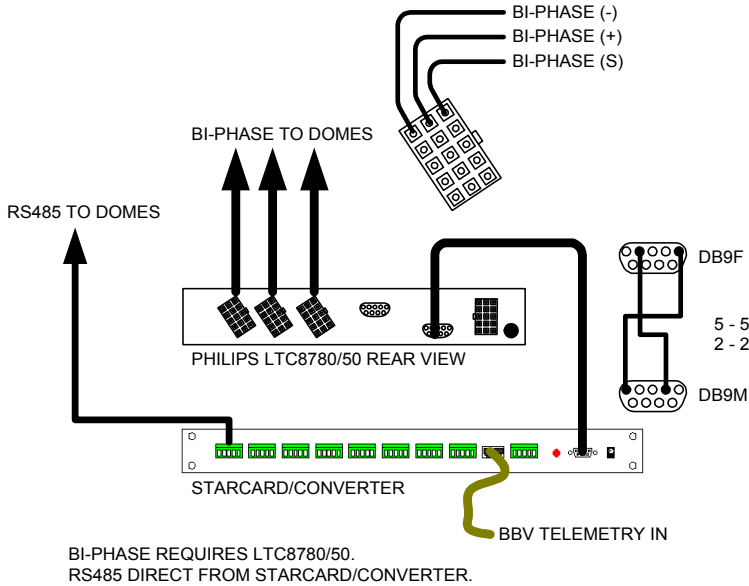

Set the dome address using the rotary switches to match the number of the camera input of the TX1500. Ensure that any dome at the end of a daisy chained RS485 run has the RS485 terminated and the intermediate domes have the RS485 de-terminated.

If the dome only supports FastAddress™, a Philips controller must be used to set the dome address before installation. The 1-2-1 converter will not set the FastAddress™.

Dome Function	TX1500 Procedure
SET/SAVE PRESET (1-64)	PROGRAM NUMBER PRESET
SHOW/GOTO PRESET (1-64)	NUMBER PRESET
DISPLAY DOME MENU (AUX 46 ON)	1 #
PROGRAM ZONE TITLE (AUX 63 ON)	2 #
AUTOPLAY RECORD (AUX 100 ON/OFF)	3 # to start recording followed by either 3 # or AUTOPAN to stop recording.
DISPLAY SOFTWARE VERSION (AUX 66 ON)	4 # TWO times
RESET DOME (SET 899)	4 # FOUR times <i>(This will erase all preset positions and load default dome settings – use with care!)</i>
START DOME PRESET TOUR (AUX 8 ON)	1 PATROL
START AUTOPLAY PLAYBACK (AUX 50 ON)	AUTOPAN
DISPLAY PRESET TOUR MENU (SET 900)	PROGRAM 99 PRESET
DISPLAY PRESET TOUR PERIOD (AUX 15 ON)	PROGRAM 98 PRESET
DISPLAY PRESET MENU (SET 100)	PROGRAM 97 PRESET

PHOTOSCAN FIXED SPEED PAN/TILT from BBV telemetry only

The following functionality is provided:

Fixed speed Pan/Tilt

Zoom/Focus/Iris

WIPE drives the WI aux output

WASH drives the WA aux output

AUTOPAN drives the A2 output

LIGHTS has not been tested due to faulty receiver.

SW4



Star output

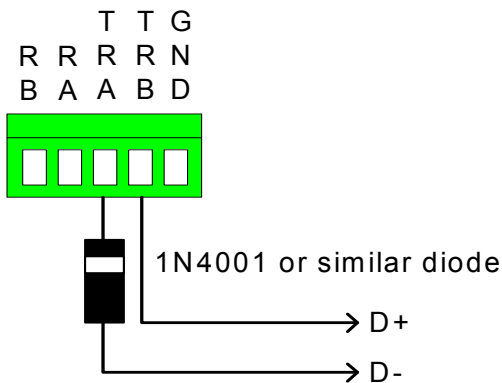

Photoscan receivers are driven using current loop telemetry.

The output of the 1-2-1 converter must have a diode fitted to each output as shown in the diagram on the left to allow control of the Photoscan units.

It is possible for the receivers to function without the diode but it is recommended that the diode is fitted to reduce the reverse voltage on the receiver's opto isolator input.

It is possible to connect multiple receivers to each star output this is not recommended.

NOTES:

1. PLEASE READ THIS CAREFULLY FIRST.

Controlling more than one camera at the same time will cause intermittent telemetry control. This is because the 1-2-1 converter repeats commands to moving cameras. Receivers with a different address will stop moving until their command is repeated.

Switching SW4/8 ON will disable the command repeats, but could cause control problems with Photo Scan domes.

2. Ensure that switches SW1/3&4 must be OFF. This disables the RS422 termination. Poor telemetry control can result if these switches are not off.
3. The 1-2-1 converter does NOT send a power up message when Photoscan protocol is selected because this will cause the telemetry receivers to move the camera as the protocol does not use checksums.

Samsung SCC641/643 dome and SCC421 camera from BBV telemetry only

SCC641/643 dome

Connect dome RXD/+ to Converter TA and dome RXD/- to Converter TB.

Set the dome address using the SW500 switch to match the number of the camera input of the TX1500. SW501 all off apart from 3 and 5 to select 9600 BAUD, SAMSUNG protocol and FULL duplex.

SW4



Ensure that any dome at the end of a daisy chained RS485 run are have switches SW401/1 and SW401/2 ON to terminate the RS485 terminated and the intermediate domes have the SW401/1 and SW401/2 OFF.

The following functionality is provided.

Manual pan/tilt control with 16 speed steps.

Zoom with Manual Focus override.

Operating the Zoom will re-enable auto focus after manual adjustment

64 preset positions.

AUTOPAN can be started with the AUTOPAN key.

PRESET SCAN can be started using 1 PATROL.

PATTERN 2 can be started using 2 PATROL.

The patterns are defined from the dome menu which is accessed using 1 # as below.

Advanced Function	TX1500 Procedure
Dome Menu ON	1 #
Dome Menu OFF	2 #
Dome Menu ENTER	3 #
Start PRESET SCAN	1 PATROL
Start PATTERN 2	2 PATROL
Start AUTOPAN	AUTOPAN

SCC421P Static camera

Connect the camera RS485 Data+ to 1-2-1 converter TA and Data- to 1-2-1 converter TB.

Ensure that BAUD RATE is set to 9600 and RS485 ADDR is set to match the video input on the Tx1500 matrix. The buttons on the rear of the camera allow menu access.

Ensure that any camera at the end of a daisy chained RS485 run has the TERMINATION switch ON and the intermediate camera have the TERMINATION switch OFF.

The following functionality is provided.

Zoom with Manual Focus override.

To allow manual focus set AUTO FOCUS in the menu to either ONEAF for MF.

ONEAF will cause an AUTOFOCUS after a zoom and MF is permanently in manual focus mode.

Iris Open/Close.

Sensormatic RS422 from BBV telemetry only

SW4



Connect dome RS422 IN + to 1-2-1 converter TA and RS422 IN- to 1-2-1 converter TB.
Set the dome address to match the number of the camera input of the matrix.

The following functionality is provided.

Variable speed Pan/Tilt

Zoom/Focus/Iris

64 preset positions.

Menu access and navigation

Pattern #1 record and playback

Additional Dome features

Dome Function	TX1500 Keystroke
PATTERN #1 RECORD	1 # - start recording Move dome pan/tilt/zoom 1# - end recording (Note the dome does not support variable speed pan/tilt when recording a pattern)
PATTERN #1 PLAYBACK	AUTOPAN
DISPLAY DOME MENU	4 # Navigate with joystick Focus is ENTER and ZOOM toggles options.

VCL TP – Fixed at 9600,N,8,1 (adjust SW3 to suit input protocol)

SW4

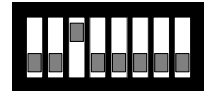

Connect dome D+ to 1-2-1 Converter TA and dome D- to 1-2-1 Converter TB.

Set the dome address using the DIL switch to match the number of the camera input of the TX1500. Ensure that any dome at the end of a daisy chained RS485 run are have the RS485 terminated and the intermediate domes have the RS485 de-terminated.

The following functionality is provided.

Manual pan/tilt control with 16 speed steps from 1 to 127, (slowest to fastest)

Zoom with Manual Iris and Focus override.

Operating the Zoom will re-enable auto focus and iris after manual adjustment

32 preset positions.

2 sequential preset tours of preset positions 1 - 16, tour 1 maximum speed and tour 2 speed 32. The dwell time is fixed at 10 seconds per preset position. Preset positions can be removed from the tours.

All 28 privacy zones can be programmed and disabled if required.

Advanced Function	TX1500 Procedure
Manual 180 degree pan flip (U turn)	1 #
Program a privacy zone	2 # followed by PROGRAM 1-28 PRESET
Clear a privacy zone	3 # followed by PROGRAM 1-28 PRESET
Dome remote reset (power cycle)	4 #
Add preset position to the tours	Programming a preset position adds the preset into the tour. (1 – 16 only)
Remove a preset from the tours	PROGRAM 50 PRESET followed by 1-16 PRESET
Start preset tour 1 – high speed	1 PATROL (max speed with 10 second dwell)
Start preset tour 2 – slow speed	2 PATROL (speed 32 with 10 second dwell)
Start Learned tour 5	AUTOPAN (must be defined with PROGRAM 56 PRESET as below)
Set Home functions (fixed at 5 minutes)	PROGRAM 54 PRESET followed by 1 PRESET = Enable to preset 1 2 PRESET = Enable to tour 1 (fast) 3 PRESET = Enable to tour 2 (slow) 4 PRESET = Enable to learned tour (autopan) 5 PRESET = Disable home
Reset dome to factory. USE CAUTION!! This command will clear all dome configuration including preset positions.	PROGRAM 55 PRESET followed by PROGRAM 55 PRESET
Define learned tour 5 – START	PROGRAM 56 PRESET
Define learned tour 5 – STOP	PROGRAM 57 PRESET
Enable AUTO180 pan flip	PROGRAM 58 PRESET

VCL TP – When using Pelco input protocol

Advanced Function	Pelco procedure
180 degree pan flip (U turn)	SAVE PRESET 95
Program a privacy zone	GOTO PRESET 33 followed by PROGRAM 1-28 PRESET
Clear a privacy zone	GOTO PRESET 94 followed by PROGRAM 1-28 PRESET
Dome remote reset (power cycle)	Head reset
Add preset position to the tours	Saving a preset position adds the preset into the tour. (1 – 16 only)
Remove a preset from the tours	PROGRAM 50 PRESET followed by GOTO PRESET 1-16
Start preset tour 1 – high speed	GOTO PRESET 97 (max speed with 10 second dwell)
Start preset tour 2 – slow speed	GOTO PRESET 98 (speed 32 with 10 second dwell)
Start Learned tour 5	GOTO PRESET 99 (must be defined with SAVE PRESET 56 as below)
Set Home functions (fixed at 5 minutes)	PROGRAM 54 PRESET followed by GOTO PRESET 1 = Enable to preset 1 GOTO PRESET 2 = Enable to tour 1 (fast) GOTO PRESET 3 = Enable to tour 2 (slow) GOTO PRESET 4 = Enable to learned tour (PRESET 99) GOTO PRESET 5 = Disable home
Reset dome to factory. USE CAUTION!! This command will clear all dome configuration including preset positions.	SAVE PRESET 55 followed by SAVE PRESET 55
Define learned tour 5 – START	SAVE PRESET 56
Define learned tour 5 – STOP	SAVE PRESET 57
Enable AUTO180 pan flip	SAVE PRESET 58

SW3

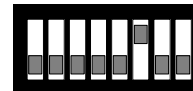

SW4



VCL TP – from 360 Vision Protocol

From 360 Vision matrix, connect Data+ to solid blue wire into 1-2-1 converter and Data- to white/blue wire into 1-2-1 converter. Connect dome D+ to STAR TA and dome D- to STAR TB.

Set the dome address using the DIL switch to match the number of the camera input of the matrix. Ensure that any dome at the end of a daisy chained RS485 run are have the RS485 terminated and the intermediate domes have the RS485 un-terminated.

The following functionality is provided.

Pan/Tilt/Zoom/Focus/Iris

Auto/Manual Focus and Iris switching

127 preset positions

Tour 1-4 definition and playback, preset 1-127 and dwell of 2-254 seconds (2 second increments)

Mimic Tour 1-4 definition and playback (VCL tour 5-8)

Privacy zones 1-28 can be programmed and toggled ON/OFF (VCL preset 100-127)

180 degree flip enable/disable on tilt down

Home functions, preset 1-127 or tour 1-4 with 1-127 minute delay

A1 and A2 toggle dome mono/colour but dome will auto switch back to colour if the scene is bright enough.

LOCK A3 – toggles Wiper ON/OFF (in CONV1_V24 and later software)

Please read the 360 Vision keyboard manual for details of keystrokes etc.

Vicon Surveyor from BBV telemetry only

SW4

Connect dome COMM_IN+ to 1-2-1 Converter TA and dome COMM_IN- to 1-2-1 Converter TB.



Set the dome address using the DIL switch to match the number of the camera input of the TX1500. Ensure that any dome at the end of a daisy chained RS485 run are have the RS485 terminated and the intermediate domes have the RS485 de-terminated.

Select VPS telemetry using dome DIP DIL.

The following functionality is provided.

Manual pan/tilt control with 16 speed steps.

Zoom with Manual Focus override.

Operating the Zoom will re-enable auto focus after manual adjustment

64 preset positions.

3 tours can be started, tour 81 and 82 using 1 PATROL and 2 PATROL and tour 80 with AUTOPAN.

The tours are defined from the dome menu.

Advanced Function	TX1500 Procedure
Display dome menu	1 #
MENU AP – ENTER	IRIS OPEN
MENU AI – ESCAPE	IRIS CLOSE
AUX 1	WASH
AUX 2	WIPE
AUX 3	LIGHTS
Start TOUR 81	1 PATROL
Start TOUR 82	2 PATROL
Start TOUR 80	AUTOPAN

It is very important that once you have exited the dome menu you send a 1 PRESET to inform the 1-2-1 converter that you are out of the dome menu.

The output baud rate can be selected between 4800 and 9600 baud. SW4/8 ON = 4800 baud, SW4/8 OFF = 9600 baud. Generally 9600 baud will be used on late systems and 4800 baud on early systems.

Support for earlier V1305DC DC telemetry receivers.

SW4/7 ON and SW4/8 ON

These receivers use 4800 baud so SW4/8 must be ON.

SW4/7 must also be ON to enable control of this receiver type. When in this mode, the WASH function drives Aux 4 which is the only momentary output.

VIDECON VCP451 CAMERA from BBV telemetry only

Connect the twisted pair as follows:
Camera RS485+ to 1-2-1 converter TA
Camera RS485- to 1-2-1 converter TB

SW4



The following functionality is provided:
ZOOM, FOCUS
Menu Access

Advanced Dome features

Dome Function	TX1000 Keystroke	TX1500 Keystroke
DISPLAY MENU Use the joystick to navigate the menu or zoom for up/down and focus for left/right	hold # and tap WASH	1 #

Note:

Use the MENU switch on the camera to set the following before connecting to the 1-2-1 converter.
CAMERA ID – This must match the camera input of the matrix
PROTOCOL – P/D to allow control (PELCO D, 2400,N,8,1)

The camera uses the zoom and focus functions whilst navigating the menu to make it easier to use the joystick. Pan generates zoom and tilt generates focus even when not displaying the dome menu. This is NOT a fault!

For more information please refer to the camera handbook.

VIDECON VHSD 860 DOME from BBV telemetry only

Connect the twisted pair as follows:

Dome D+ to 1-2-1 converter TA

Dome D- to 1-2-1 converter TB

SW4



The following functionality is provided:

Variable speed Pan/Tilt

Zoom/Focus/Iris

64 preset positions

Menu Access

Privacy Menu Access

Pattern Tour 1 define and playback, Auto Patrol playback, Frame Scan playback

Advanced Dome features

Dome Function	TX1000 Keystroke	TX1500 Keystroke
DISPLAY MENU	hold # and tap WASH	1 #
DISPLAY PRIVACY MENU	hold # and tap WASH	2 #
DEFINE PATTERN 1 START	hold # and tap AUTOPAN	3 #
DEFINE PATTERN 1 STOP	hold # and tap LIGHTS	4 #
PATTERN 1 PLAYBACK	AUTOPAN	AUTOPAN
AUTO PATROL PLAYBACK	hold PATROL and tap 1	1 PATROL
FRAME SCAN PLAYBACK	hold PATROL and tap 2	2 PATROL
IR FILTER ON/OFF	Not possible	ON (MONO) 89 PRESET OFF (COLOUR) 88 PRESET

Note:

Please ensure the three dome switches are set as follows:

Dome back plate 4 way switch – ALL OFF to select PELCO P

Dome 2 way switch – BOTH ON to select 9600 BAUD

Dome 8 way switch – set the address to match the camera input of the matrix

For more information please refer to the dome handbook.

VIDEOTEC ULISSE (PELCO D) from BBV telemetry only

SW4

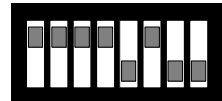

Connect the twisted pair as follows:
Ulisse 485/A to 1-2-1 converter TA
Ulisse 485/B to 1-2-1 converter TB

Ulisse Switch settings
BAUD RATE – 4 ON, 3 OFF, 2 ON, 1 OFF
PROTOCOL – 1 ON, 4 ON, ALL OTHERS OFF
ADDRESS – 9 ON, 1-8 SETS THE ADDRESS AS ULISSE MANUAL

The following functionality is provided:

Variable speed Pan/Tilt
Zoom/Focus/Iris
64 preset positions.
Start Patrol
Start AUTOPAN
Menu access and navigation

Additional Dome features

Dome Function	TX1000 Keystroke	TX1500 Keystroke
DISPLAY MENU	hold # and tap WASH and navigate using the ZOOM IN = ENTER, OUT = BACK	1 # and navigate using the joystick and ZOOM IN = ENTER, OUT = BACK
AUTO WASH/WIPE	WASH SW4/8 = OFF (factory default)	WASH SW4/8 = OFF (factory default)
RELAY O1/C1	WASH SW4/8 = ON	WASH SW4/8 = ON
WIPE	WIPE	WIPE
LIGHTS O2/C2	LIGHTS	LIGHTS
START PATROL	HOLD 1 TAP PATROL	1 PATROL
AUTOPAN	AUTOPAN	AUTOPAN

Note:

WASH function can either control Ulisse relay output O1/C1 or to start the head auto wash/wipe feature.

SW4/8 is used to switch between these modes. The factory setting is with SW4/8 OFF = WASH starts the auto wash/wipe function.

Head moves to Preset 1, the WASH is activated for a time set in the head menu and then the Wiper operates for another time configured in the head menu before returning the head to the original position.

If this feature is not required the O1/C1 relay can be controlled instead by switching SW4/8 ON.

For more information please refer to the Ulisse handbook.

Vista PowerDome from BBV telemetry only

SW4



Connect dome DATA IN A/+ to Starcard Converter TA and dome DATA IN B/- to Starcard Converter TB.

Set the dome address using the DIL switch to match the number of the camera input of the TX1500. Ensure that any dome at the end of a daisy chained RS485 run are have the RS485 terminated and the intermediate domes have the RS485 de-terminated.

The following functionality is provided.

Manual pan/tilt control with 16 speed steps.

Zoom with Manual Focus override.

Operating the Zoom will re-enable auto focus after manual adjustment

64 preset positions.

3 tours can be started, TOUR 1 and 2 using 1 PATROL and 2 PATROL and LEARN TOUR 1 with AUTOPAN.

The tours are defined from the dome menu which is accessed using 1 # as below.

Advanced Function	TX1500 Procedure
Display dome menu	1 #
Menu – ENTER	2 #
Menu – ESCAPE	3 #
Start TOUR 1	1 PATROL
Start TOUR 2	2 PATROL
Learn 1 playback	AUTOPAN

Extend your BBV Warranty from 12 months to 3 years

As of the 1st September 2008 BBV have offered our customers the opportunity to extend the standard 12 month warranty to 3 years.

You must register for the extended warranty within 12 months of the date of manufacture.

How to register for the 3 year warranty

Registering for the new, longer 3 year warranty term is quick and easy.

Either:

Complete the warranty application card that comes in the box with your BBV product, and return it FREEPOST to BBV:

 **BBV 3 Year Warranty**

If this card is returned with the serial number of the product and the installation company details BBV will extend the warranty period from 12 Months to 36 Months.

Number of Units, Start Serial No. Final Serial No.

Contact Name _____
Company Name _____
Phone Number _____
Site Name _____
Address 1 _____
Address 2 _____
Address 3 _____
Post Code _____
e-mail address _____

Please could you send me information especially on:
 Rx100s
 Rx45x & Rx55x
 FBV Video Matrices
 Tx1500 Video Matrices
 Starcard & Starcard Converters
 BBV Quad
 Pick A Point

Do you read  PSI MAGAZINE?
 I do not require any other product information.
Please refer to WWW.BBVCTV.COM for terms, conditions & exclusions

VAT Reg. No. 621756339 Registered in England No. 262921 Registered office: 17 Apex Park Dobbies Way, Halesham East Sussex UK BN27 3JU

Or alternatively:

Register online at: www.bbvctv.com
Simply enter your details on the 'Warranty Cover' page.

Building Block Video Ltd

Tel: + 44 (0) 1323 842727
Fax: + 44 (0) 1323 842728
Support: + 44 (0) 1323 444600
www.bbvctv.com

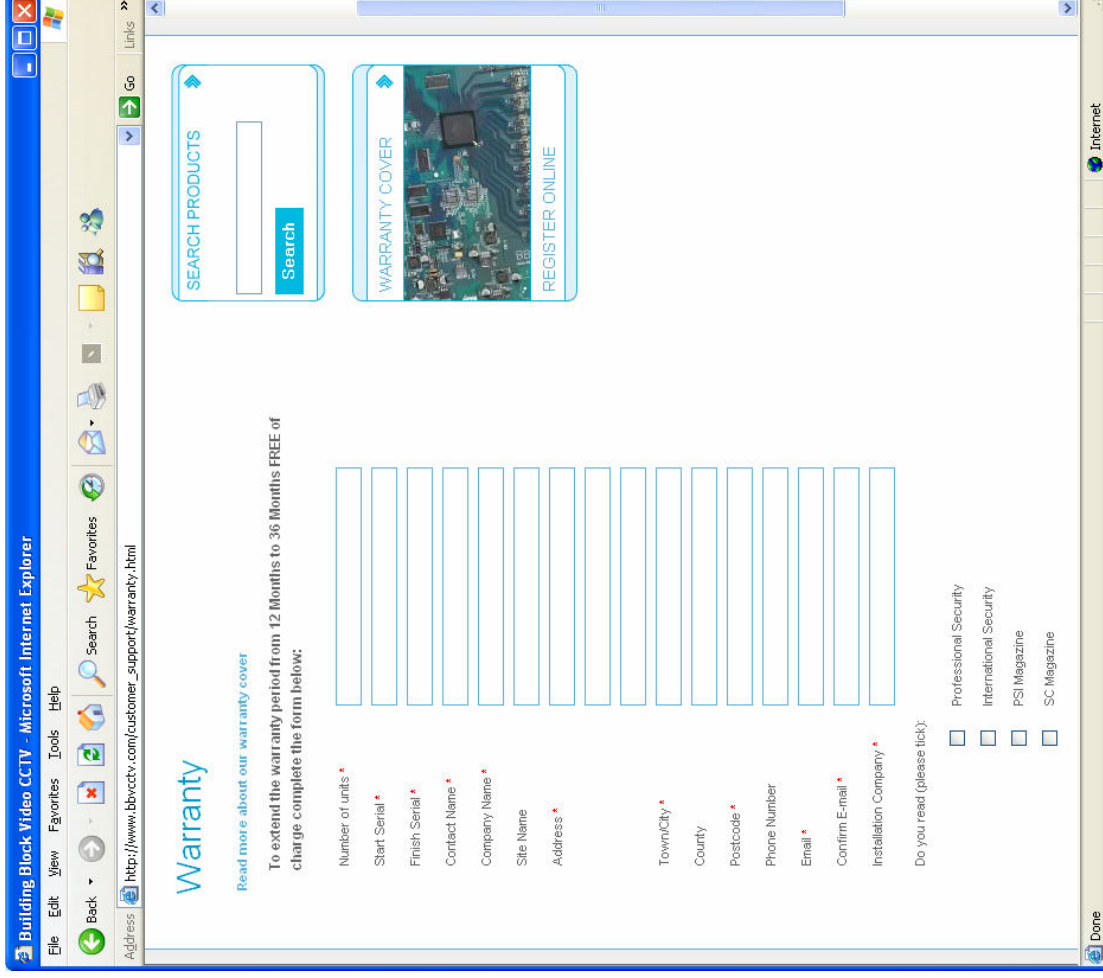

Warranty

Read more about our warranty cover

To extend the warranty period from 12 Months to 36 Months FREE of charge complete the form below:

Number of units *
Start Serial *
Finish Serial *
Contact Name *
Company Name *
Site Name
Address *
Town/City *
County
Postcode *
Phone Number
Email *
Confirm E-mail *
Installation Company *

Do you read (please tick):

Professional Security
 International Security
 PSI Magazine
 SC Magazine