



Tamper Safe



Installation Guide



Building Block Video Ltd.,
17 Apex Park,
Diplocks Industrial Estate,
Hailsham, East Sussex, BN27 3JU UK.
Tel: +44(0)1323 842727
Fax: +44(0)1323 842728
Support: +44(0)1323 444600
www.bbvctv.com

TABLE OF CONTENTS

1. Pre-installation Checks and Safety Procedures	4
Unpacking	4
Important safety precautions	4
2. Introduction & Installation	6
Tamper Safe specification	6
General	7
Quick Setup Guide	7
Day Mode	8
Video Failure	8
Communications Failure	8
Tamper	8
Power	8
3. Configuration Utility Quick Start Guide	9
Using the application to configure the tamper safe	10
4. Appendix	12

PRE-INSTALLATION CHECKS AND SAFETY PROCEDURES

UNPACKING

Check Packaging - Upon taking delivery of the unit, inspect the packaging for signs of damage. If damage has occurred, advise the carriers and/or the suppliers immediately.

Check Contents - Upon taking delivery of the unit, unpack the unit carefully and check that all the items are present and correct. If any items are missing or damaged, contact your equipment dealer.

Retain Packaging - The shipping carton is the safest container in which to transport the unit. Retain undamaged packaging for possible future use.

IMPORTANT SAFETY PRECAUTIONS

Read Instructions - All relevant safety, installation and operating instructions should be read before attempting to install, connect or operate the unit.

Retain Instructions - All safety, installation and operating instructions should be retained for future reference.

Heed Warnings - All warnings on the unit and in any relevant safety, installation or operating instructions should be adhered to.

Cleaning - Unplug the unit from the power outlet before cleaning. Do not use liquid cleaners or aerosol cleaners. Use a damp cloth for cleaning.

Attachments - Do not use attachments not recommended by the product manufacturer as they may cause hazards.

Water and Moisture - Do not expose the internal electronics of this unit to water or moisture; for example, in an unprotected outdoor installation, or in any area classified as a wet location. The unit as supplied conforms to ingress protection rating IP 67. This rating will be affected by any holes made in the enclosure. Cable entry points should be protected by the use of suitably rated glands and/or flexible conduit. It is not necessary to make further holes in the enclosure for mounting purposes, as mounting holes are provided at the corners of the enclosure outboard of the seal between enclosure and lid.

Accessories - Do not attach this unit to an unstable stand, bracket or mount. The unit may fall, causing serious injury to a person and serious damage to the unit.

Power Sources - This unit should be operated only from the type of power source indicated on the manufacturer's label. If you are not sure of the type of power supply you intend to use, consult your equipment dealer or local power company. For units intended to operate from battery power or other sources, refer to operating instructions.

Power Connector - This unit is equipped with coaxial power connector mounted at the edge of the PCB for low voltage power input. Do not attempt to alter this connector in any way.

Power Cord Protection - Power supply cords should be routed so that they are not likely to be trapped, pinched or otherwise damaged by items in close proximity to them, whether inside the unit or outside it. Particular attention should be paid to cords at plugs, connection units and the point of exit from the unit.

Overloading - Do not overload outlets and extension cords, as this can result in fire or electric shock.

Object and Liquid Entry - Never push objects of any kind into the unit, as they may touch dangerous voltage points or short out parts that could result in fire or electric shock. Never spill liquid of any kind on or inside the unit.

Servicing - Servicing of the unit should only be undertaken by qualified service personnel, as opening or removing covers may expose you to dangerous voltages or other hazards.

Damage Requiring Service - Servicing by qualified personnel should be carried out under the following conditions:

- (a) When the power-supply cord or plug is damaged.
- (b) If liquid has been spilled or objects have fallen into the unit
- (c) If the internal electronics of the unit have been exposed to rain or water
- (d) If the unit does not operate normally by following the operating instructions. Adjust only those controls that are covered by the operating instructions, as improper adjustment of other controls may result in damage and will often require extensive work by a qualified technician to restore the unit to normal operation.
- (e) If the unit has been dropped or the enclosure is damaged.
- (f) If the unit exhibits a distinct change in performance. This indicates a need for service.

Replacement Parts - If replacement parts are required, ensure that only replacement parts recommended by the product manufacturer are used.

Safety Check - Upon completion of any service or repairs to the unit, safety checks should be performed to ensure that the unit is in proper operating condition.

Pre-installation Checks - It is recommended that the unit be bench-tested prior to installation on the site.

Safety During Installation or Servicing - Particular care should be taken to isolate the equipment that the trigger card is plugged into in order to prevent unwanted alarms at a control room.

Adhere to Safety Standards - All normal safety precautions as laid down by British Standards and the Health and Safety at Work Act should be observed.

TAMPER SAFE TECHNICAL SPECIFICATION

Power Requirements: 230vac

Current Consumption: 3 Amps

Features:

- PC Based Configuration Interface
- USB DATA interface.
- 21 alarm inputs.
- Battery Back-up

Engineering Facilities:

- LED readout for continual system status.
- Video OSD.

Video Input: PAL or NTSC 1v p-p 75 Ω terminated input via BNC socket.
Video Output: PAL or NTSC 1v p-p to 4v p-p 75 Ω impedance via BNC socket.

Dimensions (external):

Width: 330 mm
Length: 350 mm
Height: 080 mm

Weight: 5.5Kg

Temperature range: -10° Celsius to +40° Celsius

General

Tamper Safe Board Information sheet

This board is designed to interface between alarm circuits and an ADPRO unit. FAST TRACE, FAST VIEW, FAST SCAN. The unit upgrades existing sites to BS8418 allowing a single pair of wires to detect both tamper and alarm events.

The unit allows for 19 alarm circuits, a fire input, a panic input and three hardwired inputs. The fire and alarm inputs can be reprogrammed to become general purpose alarm inputs, giving a total of 21 alarm inputs.

Day/night switch fully tamper proof,
A power fail switch, wired internally to the box power supply, and
A box tamper switch to protect itself.

The unit has a single video channel that allows alarms events to be reported on screen. The unit communicates with the ADPRO via alarm trigger boards, up to three may be fitted, and each board activates ten alarms. The unit monitors the connection between itself and the trigger boards. A failure in communications results in an on screen message and all the trigger inputs going into alarm mode.

The unit can be customised by connecting to a PC via the USB port. A specialised program is supplied by BBV (see page 9).

Quick Setup Guide

- Step 1) Connect PIR's and Fire and Tamper inputs as per diagram six in the appendix
- Step 2) Connect one of the supplied 1K2 resistor across any unused inputs
- Step 3) Connect Video as per diagram five in the appendix
- Step 4) Connect Trigger card using a Cat 5 patch cable as per diagrams 2a, 2b, 3 and 4 in the Appendix.
- Step 5) Connect mains power to the three way screw terminal connector located inside the casing as per the label located next to the terminal.
- Step 6) (Optional) Connect supplied battery leads to BATT+ and BATT - on ten way screw terminal connector located on the smaller PCB and connect spade connectors to a 12 volt 7 Ah Sealed lead acid battery (not supplied).
- Step 6) Follow Instructions on page 18 for configuring Tamper Safe using supplied software.

Day/Night Mode

When in DAY mode the unit is considered to be inactive. The default settings mean that only tamper, FIRE and PANIC alarms are reported and actioned. When in DAY mode the bottom of the screen shows a default message.

When in NIGHT mode, the Armed LED flashes and all active alarms are reported, either silently or on video (programmable using the supplied PC Software).

The unit has a feature which reports all alarms that are active for a period of time on screen, independent of the day/night setting. The time period is controlled by a global setting, the default is 3 minutes, it can be set from 1 to 99 minutes. A setting of 0 minutes disables this feature. (Programmable using the supplied PC Software).

Video Failure

The unit detects Pal/NTSC video, and detects video failure. The unit auto switches between text on video and Red screen generation on video failure. If video fails VIDEO FAILURE appears on screen and after 15 seconds the unit attempts to restore video.

Communications Failure

When Communications with the trigger boards are lost the POWER LED stops flashing and becomes solid red and COMMS FAILURE is shown on screen.

Tamper

Each alarm input has two 15 character strings associated with it one used for alarm action, the second one used for tamper detection (Programmable using the supplied PC Software). Tamper detection reports open circuit, short circuit.

Action on tamper detect

Video screen is turned red for 1 second, the first alarm contact is closed, the tamper string is placed on screen, and the second alarm contact is activated, in both day and night mode.

Power

The unit provides infused, by the PCB, 12 volt power connections to aid the installation of PIR's etc, ensure the current draw does not overload the battery, power supply unit.

CONFIGURATION UTILITY QUICK START GUIDE

Installing the Application and Device Drivers

Step 1.

Ensure the USB device is disconnected before running the installation program **Setup.exe**.

Step 2.

Run the installation program **Setup.exe** and follow the instructions. Install the application to the desired directory, the default path is "C:\Program Files\Tamper_Safe\"

Step 3.

After setup is complete ensure the device is powered and connect the device to the pc using the supplied USB cable.

Step 4.

Wait until Windows asks if it can connect to windows update to search for the driver, click on the **NO** **Not this time** option then click on the **Next** button.

Step 6.

Windows will ask if it should install from a list or a specific location, choose to manually install the drivers from a specific location, the **cdc_NTXP.ini** file can be found in the application path (default = "C:\Program Files\Tamper_Safe\").

Step 7.

Now that the drivers are installed run the application "C:\Program Files\Tamper_Safe\TamperSafe.exe"
The application will automatically scan for the connected device.

If the application fails to find the connected device a warning will appear, close the application, disconnect the device USB cable and power cycle the device.

Now reconnect the device USB cable wait for a couple of seconds before running the application again.

Using the application to configure the Tamper Safe

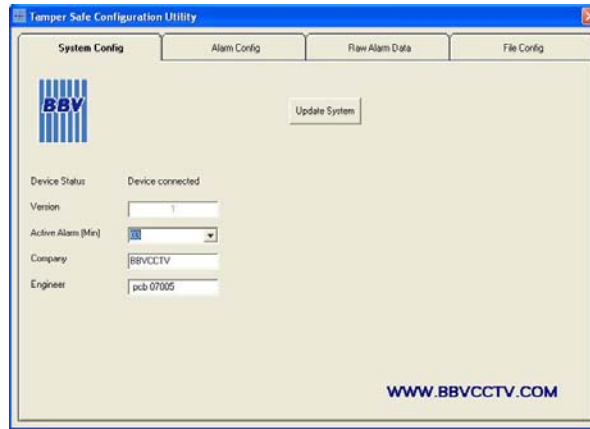

System Config:

This tab is used to view the basic system information.

- Version:** The software version within the unit (Fixed)
- Active Alarm (min):** The time in seconds that the unit waits in day mode before triggering an active alarm (Programmable)
- Company:** The installation company name max length 16 characters (Programmable)
- Engineer:** The installation engineer's name max length 16 characters (Programmable).
- Update System:** (Button) Press this to update the connected device with the new system Information.

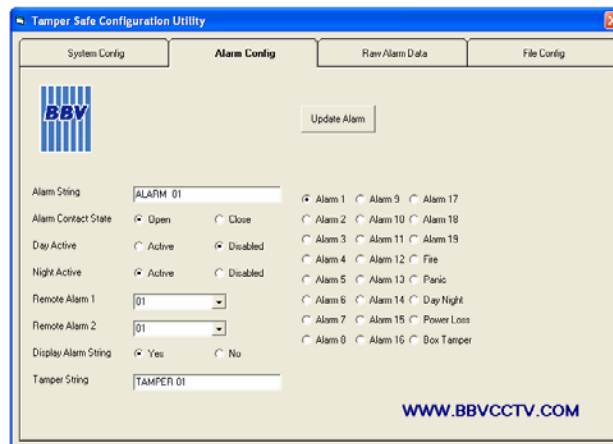

Alarm Config:

This tab is used to view the individual alarm information.

- Alarm String:** The text to be displayed on screen when an alarm is activated max length 16 characters (Programmable).
- Alarm Contact State:** The state of the alarm contacts that will cause it to be triggered, normally open or closed.
- Day Active:** Is the alarm active during the day (Programmable).
- Night Active:** Is the alarm active during the night (Programmable).
- Tamper output 1:** This output will only trigger if there is a Tamper on the input. (Programmable).
- Alarm output 2:** This output will trigger when there is an Alarm and the System in **active**. In addition the output will also trigger when there is a tamper on the input (Programmable).
- Display Alarm String:** Is the alarm text to be displayed on screen when an alarm is activated (Programmable).
- Tamper String:** The text to be displayed on screen when an alarm tamper is activated max length 16 characters (Programmable).
- Update Alarm:** (Button) Press this to update the connected device with the new alarm information.

Note: The option buttons to the left of the form are used to select the individual alarms.

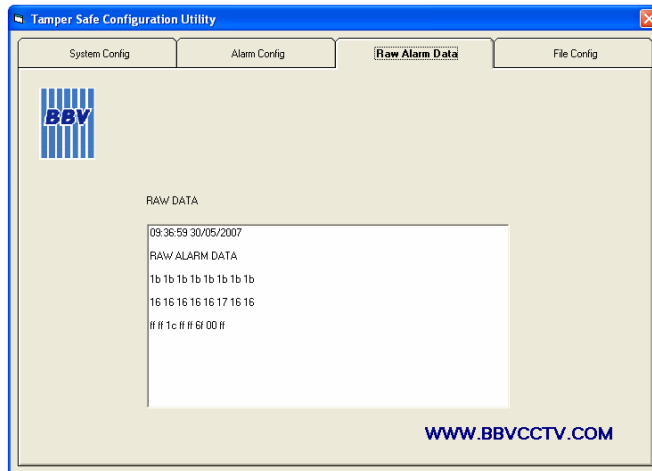

Raw Alarm Data:

This tab is used to view the raw alarm information.

The information is updated 4 times a second and displayed in the window with the time and date displayed.

This tab is designed for installation and site debugging purposes only.

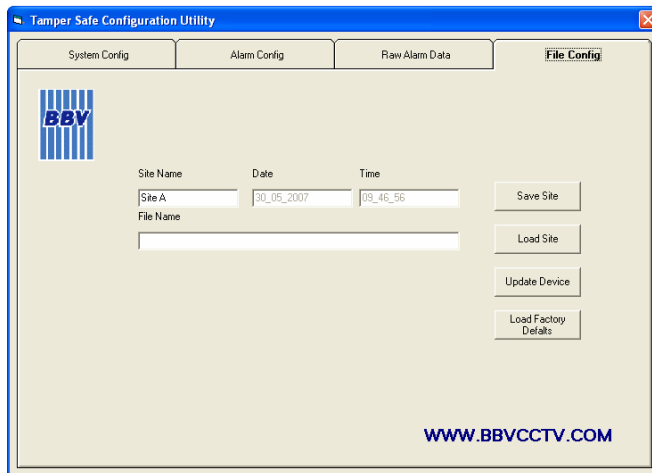

File Config:

- Site Name:** The name of the site also the name of the file to be saved (Programmable).
- File Name:** The path and name of the file that has been opened or saved (Programmable).
- Save Site:** (Button) Press this to save a copy of the information held within the connected device.
- Load Site:** (Button) Press this to load a saved site file previously saved (this does not update the device).
- Update Device:** (Button) Press this after loading a site to send all of the information to the connected device.
- Load Factory Defaults :** (Button) Press this to restore the device to its factory default settings.

Appendix

Generic Input Connection Diagram

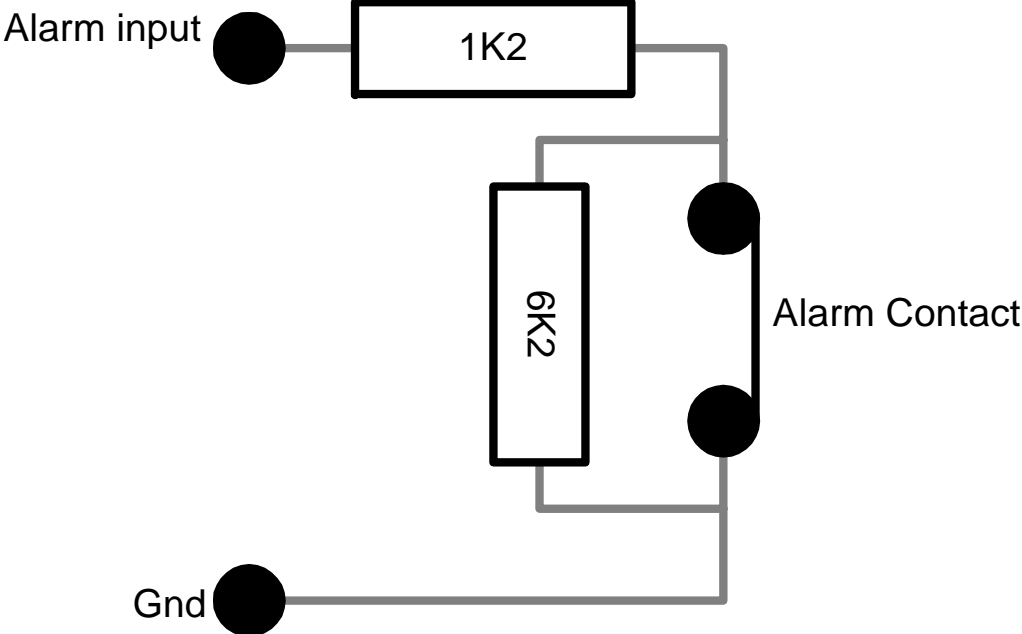
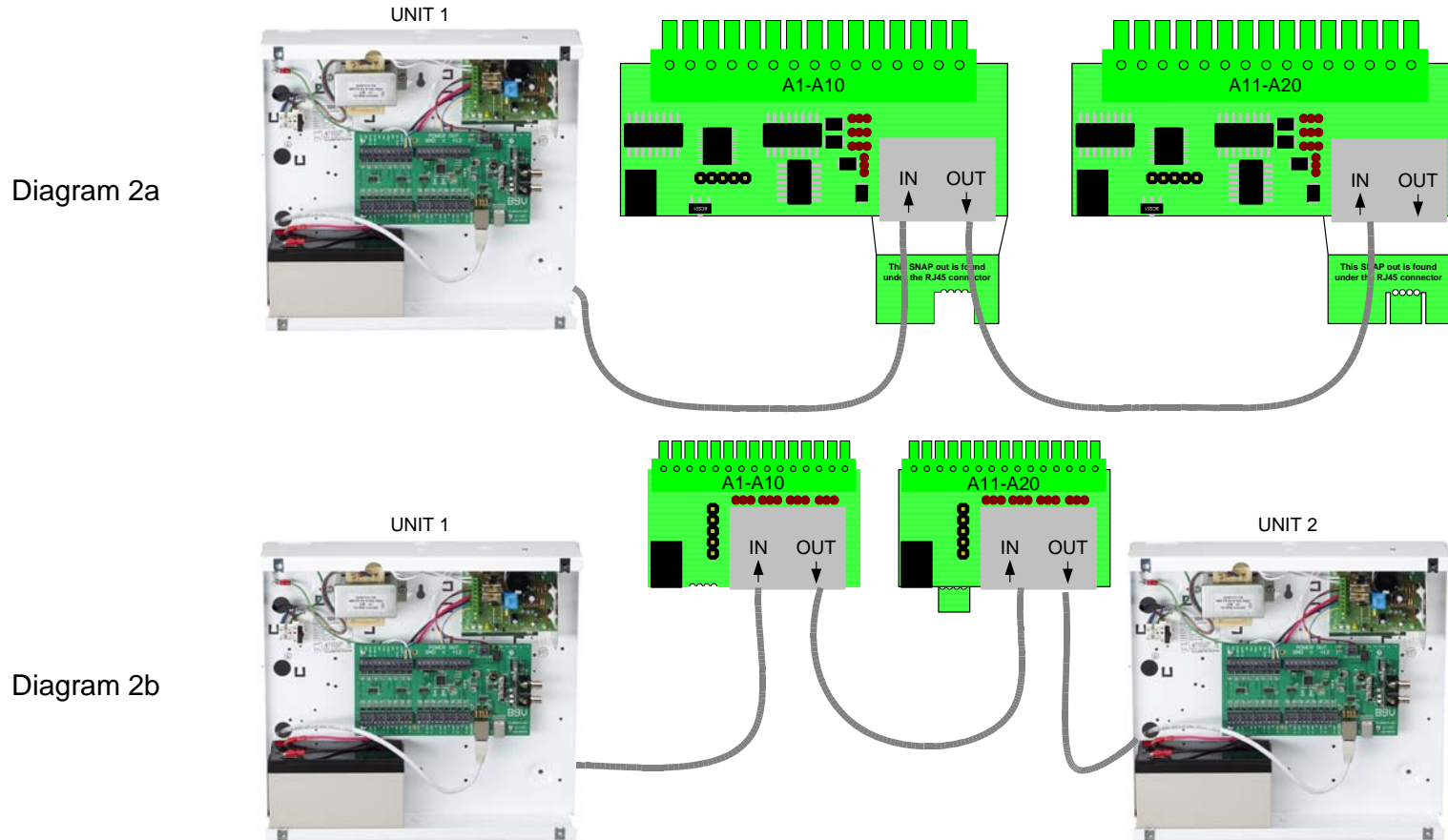

Diagram 1

Connection to trigger points is via RS422 on a standard RJ45 patch cable. The trigger units can be daisy chained. The trigger units have a snap off shunt which must be left on the last trigger unit in the chain. The trigger units may be powered via the cable or locally to the Adpro units. This method of communication saves running up to thirty pairs of cables from the alarm unit to the Adpro. The trigger units can be supplied in two varieties to suit legacy or current production Adpro units.

Different connection options



Using the Tamper Safe to protect the alarm inputs of a Dome. It can also be used in a similar manner with a standard telemetry receiver.



Diagram 4

Shown below is the interconnection between the Trigger T card and the Dome base

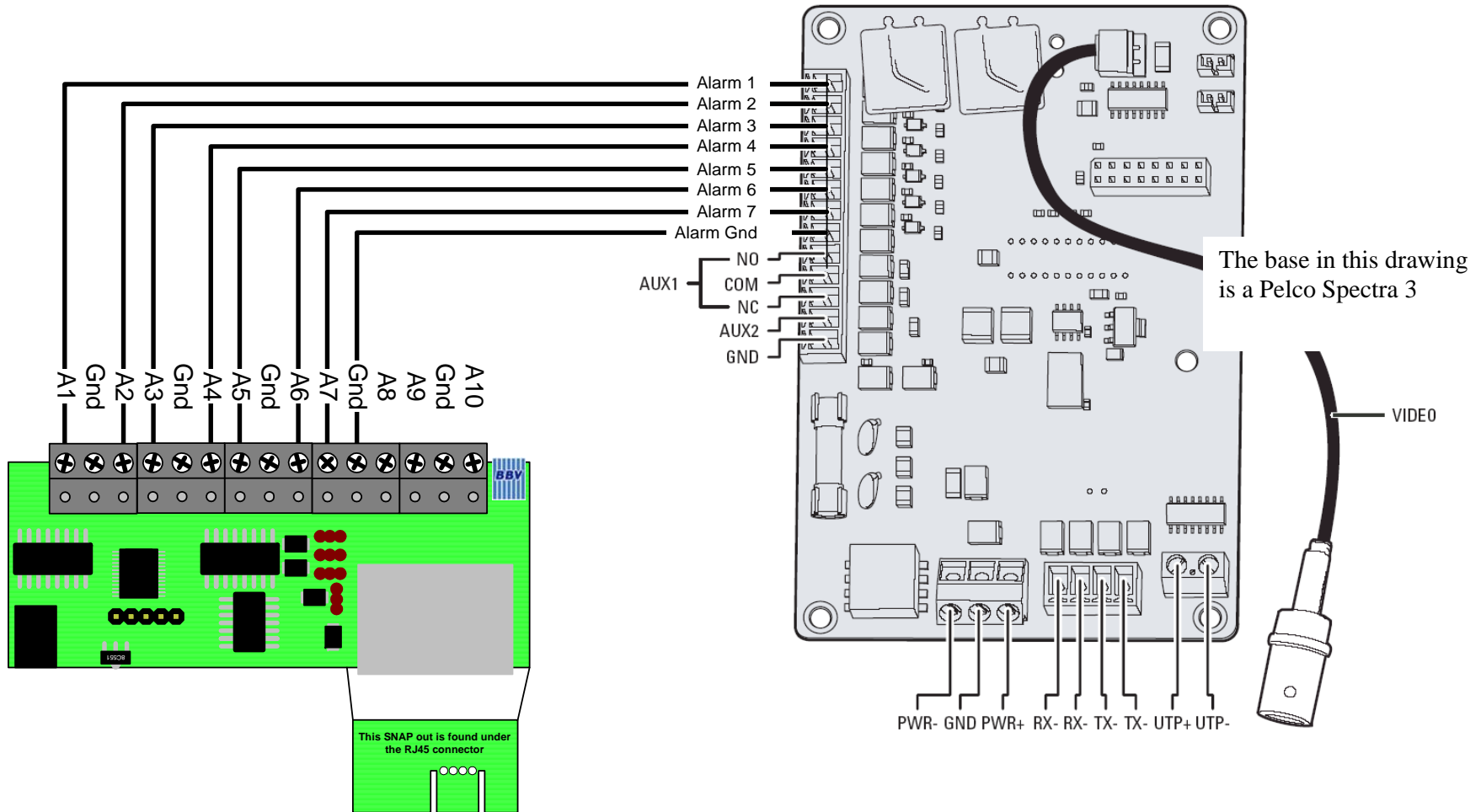

Shown below are the Video connections between a camera, the Tamper Safe and an Adpro FastTrace.

Diagram 5

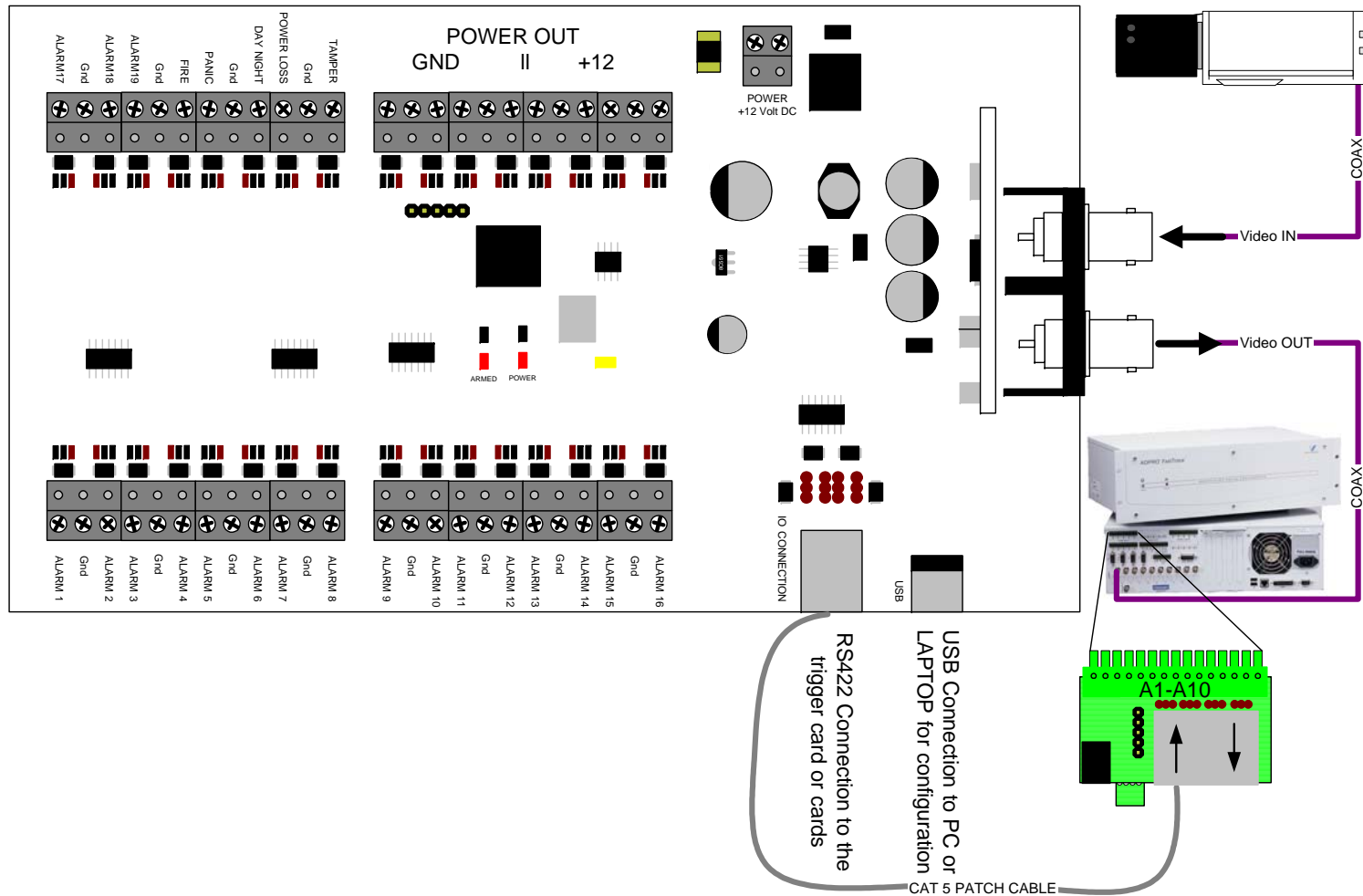

Shown below is the wiring for Redwall LRP-3020S LRP-4010 LRP-404 PIRs. All PIRs should be connected in the same manner.

Diagram 6

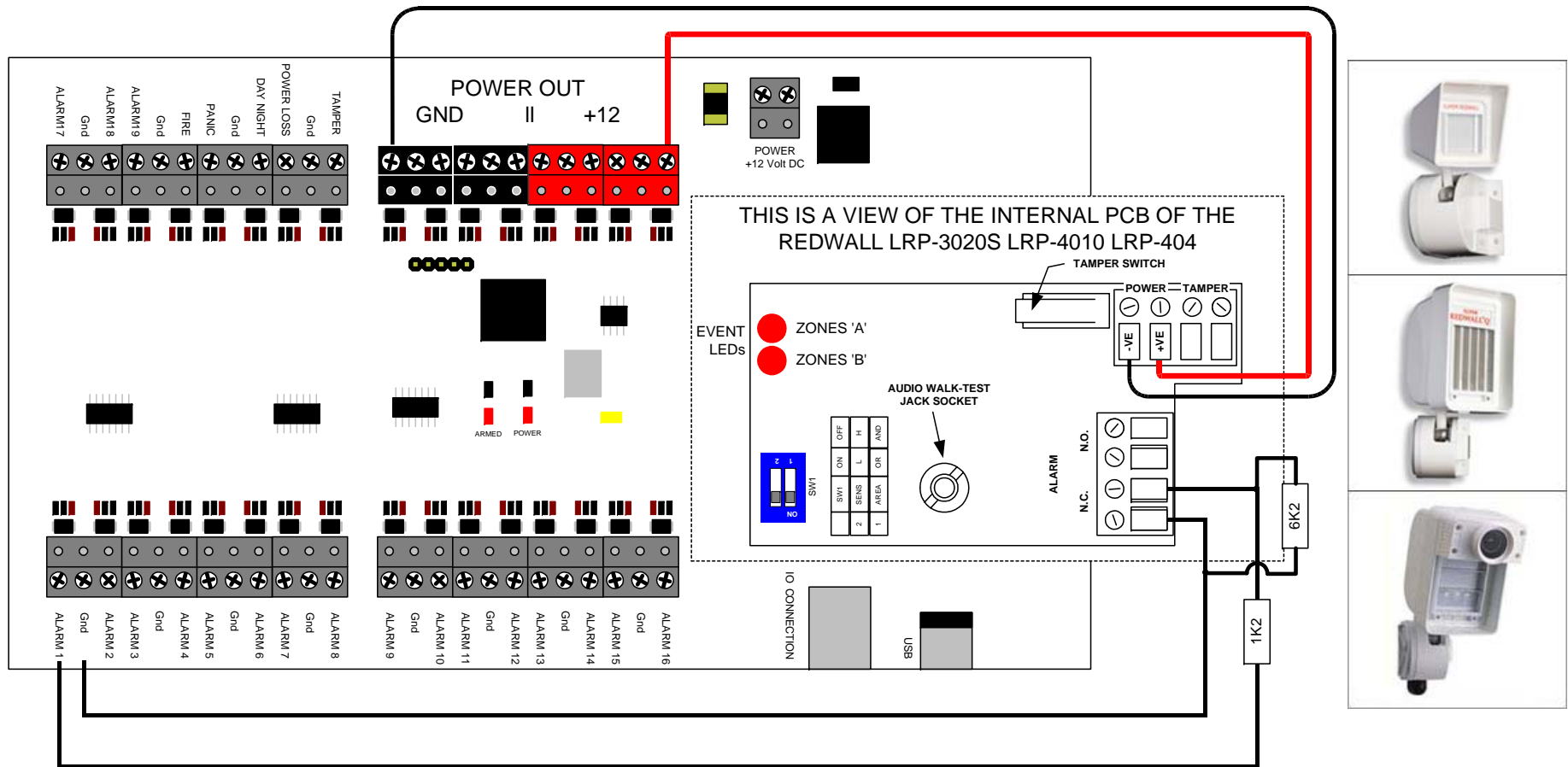

BBV products

	Description
TX400	Single camera desktop telemetry transmitter with coax & 20mA telemetry, Pan/Tilt/Lens, Lights, Wash, Wipe, Autopan, 8 presets, preset patrol.
TX400DC	As TX400 including joystick for variable Pan/Tilt control. Option of RS485 telemetry output.
TX1000 MK2	8 or 16 camera, 2 monitor telemetry transmitter. Up to 2 keyboards. BBV up-the-coax and RS422 standard with options for alarm inputs and 20mA telemetry.
TX1500	Mid size matrix 16 – 96 camera, 8 monitor. Up to 4 control positions (keyboard & remote control) options for alarms, remote control, BBV up-the-coax and RS485 telemetry.
FBM range	Large size matrix. Configurable up to 4096 cameras and 64 monitor outputs. Up to 8 control positions (keyboard & remote control) options for alarms, remote control RS485 telemetry with various options. Please call to discuss requirements.
All RX receivers below are powered by 230V ac or optional 110V or 24V ac.	
RX100	Dome Interface to drive a large library of dome cameras. BBV up-the-coax and 20mA telemetry. Mains or plugtop supply.
RX200	AC receiver for Pan only heads or static cameras, Wash/Wipe/Lights. BBV up-the-coax and 20mA telemetry.
RX300	AC receiver for Pan/Tilt/Zoom/Focus/Iris Override and 1 Auxiliary output. BBV up-the-coax and 20mA telemetry.
RX400P	AC full function receiver. PTZFI 4 Auxiliary outputs, 16 presets. BBV up-the-coax and 20mA telemetry.
RX400DC	24Vdc high/variable speed receiver. 16 presets, 8 local alarm inputs, 3 Auxiliary outputs. BBV up-the-coax and 20mA telemetry.
<p data-bbox="256 1220 586 1346">RX45X (AC) RX55X (DC)</p> <p data-bbox="285 1423 586 1535">Multi serial protocol and up-the-coax telemetry receivers</p>	<p data-bbox="634 1188 1487 1356">Multiple RS485/422 and up-the-coax controllable AC and DC receivers. PTZFI control, 32 presets, preset patrol, 8 local alarm inputs, 12V 500mA supply output. OSD for remote setup, test & diagnostics. 3 Aux. outputs RX55X or 4 Aux. outputs RX45X. Optional Privacy board.</p> <p data-bbox="634 1360 1487 1556">BBV RS422, UP-THE-COAX, 20mA current loop BAXALL STANDARD & ALTERNATE UP-THE-COAX, DENNARD RS422/485, PELCO P/D RS422/485, PHILIPS/BOSCH RS422/485 (OPTIONAL BI-PHASE INPUT), MOLYNX RS422/485, SENSORMATIC/AD RS422, VCL/HONEYWELL RS422/485, VICON RS422</p>
RX450/550	PANASONIC RS485 Protocol only version of RX45X/55X.
<p data-bbox="256 1661 586 1713">STARCARD</p> <p data-bbox="224 1724 586 1755">STARCARD/CONVERTER</p>	<p data-bbox="634 1650 1495 1703">8 * RS485 output, 2 wire simplex RS422, 4 wire full-duplex RS422, 2 wire half-duplex RS485.</p> <p data-bbox="634 1707 1495 1759">Option STARCARD/CONVERTER offering protocol conversion to drive an increasing range of 3rd party protocols.</p>
CTI 16	Multi-protocol serial converter that gives up-the-coax control to 16 cameras. BBV RS422, Dennard RS485, Pelco P, Pelco D, Philips/Bosch RS485/232, VCL RS485, Sensormatic RS422, Molyntx, Vicon
ACCESSORIES	<p data-bbox="634 1871 1170 1892">TxLD (bidirectional RS422-RS232 converter)</p> <p data-bbox="634 1896 1227 1927">98005 (bidirectional 20mA-RS232 converter)</p>

See all our products at www.bbvctv.com