



RX550 and RX450  
Panasonic RS485 receivers



# Installation Guide



Model Shown: RX550



**Building Block Video Ltd.**  
17 Apex Park,  
Diplocks Industrial Estate,  
Hailsham, East Sussex, BN27 3JU UK.  
Tel: +44(0)1323 842727  
Fax: +44(0)1323 842728  
Support: +44(0)1323 444600  
[www.bbvctv.com](http://www.bbvctv.com)

## **1. PRE-INSTALLATION CHECKS AND SAFETY PROCEDURES**

### **UNPACKING**

**Check Packaging** - Upon taking delivery of the unit, inspect the packaging for signs of damage. If damage has occurred, advise the carriers and/or the suppliers immediately.

**Check Contents** - Upon taking delivery of the unit, unpack the receiver carefully and check that all the items are present and correct. If any items are missing or damaged, contact your equipment dealer.

**Retain Packaging** - The shipping carton is the safest container in which to transport the unit. Retain undamaged packaging for possible future use.

### **IMPORTANT SAFETY PRECAUTIONS**

**Read Instructions** - All relevant safety, installation and operating instructions should be read before attempting to install, connect or operate the unit.

**Retain Instructions** - All safety, installation and operating instructions should be retained for future reference.

**Heed Warnings** - All warnings on the unit and in any relevant safety, installation or operating instructions should be adhered to.

**Cleaning** - Unplug the unit from the power outlet before cleaning. Do not use liquid cleaners or aerosol cleaners. Use a damp cloth for cleaning.

**Attachments** - Do not use attachments not recommended by the product manufacturer as they may cause hazards.

**Water and Moisture** - Do not expose the internal electronics of this unit to water or dampness; for example, in an unprotected outdoor installation, or in any area classified as a wet location. The unit as supplied conforms to ingress protection rating IP 67. This rating will be affected by any holes made in the enclosure. Cable entry points should be protected by the use of suitably rated glands and/or flexible conduit. It is not necessary to make further holes in the enclosure for mounting purposes, as mounting holes are provided at the corners of the enclosure outboard of the seal between enclosure and lid.

**Accessories** - Do not attach this unit to an unstable stand, bracket or mount. The unit may fall, causing serious injury to a person and serious damage to the unit.

**Power Sources** - This unit should be operated only from the type of power source indicated on the manufacturer's label. If you are not sure of the type of power supply you intend to use, consult your equipment dealer or local power company. For units intended to operate from battery power or other sources, refer to operating instructions.

**Power Connector** - This unit is equipped with connector mounted at the edge of the PCB for mains power input. Do not attempt to alter this connector in any way.

**Power Cord Protection** - Power supply cords should be routed so that they are not likely to be trapped, pinched or otherwise damaged by items in close proximity to them, whether inside the unit or outside it. Particular attention should be paid to cords at plugs, connection units and the point of exit from the unit.

**Overloading** - Do not overload outlets and extension cords, as this can result in fire or electric shock.

**Object and Liquid Entry** - Never push objects of any kind into the unit, as they may touch dangerous voltage points or short out parts that could result in fire or electric shock. Never spill liquid of any kind on or inside the unit.

**Servicing** - Servicing of the unit should only be undertaken by qualified service personnel, as opening or removing covers may expose you to dangerous voltages or other hazards.

**Damage Requiring Service** - Servicing by qualified personnel should be carried out under the following conditions:

- (a) When the power-supply cord or plug is damaged;
- (b) If liquid has been spilled, or objects have fallen into, the unit;
- (c) If the internal electronics of the unit have been exposed to rain or water;
- (d) If the unit does not operate normally by following the operating instructions. Adjust only those controls that are covered by the operating instructions, as improper adjustment of other controls may result in damage and will often require extensive work by a qualified technician to restore the unit to normal operation;
- (e) If the unit has been dropped or the enclosure is damaged;
- (f) If the unit exhibits a distinct change in performance. This indicates a need for service.

**Replacement Parts** - If replacement parts are required, ensure that only replacement parts recommended by the product manufacturer are used.

**Safety Check** - Upon completion of any service or repairs to the unit, safety checks should be performed to ensure that the unit is in proper operating condition.

**Coax Grounding** - If an outside cable system is connected to the unit, be sure the cable system is grounded.

**Pre-installation Checks** - It is recommended that the unit be bench-tested prior to installation on the site.

**Safety During Installation or Servicing** - Particular care should be taken to isolate the pan/tilt head in order to prevent operation while engineering work is being carried out on the receiver.

**Adhere to Safety Standards** - All normal safety precautions as laid down by British Standards and the Health and Safety at Work Act should be observed.

## **WARNING**

TO PREVENT DANGER OF FIRE OR SHOCK, DO NOT EXPOSE THE INTERNAL COMPONENTS OF THIS EQUIPMENT TO RAIN OR MOISTURE.

DO NOT OPERATE THE UNIT WITH ANY INTERNAL COVERS REMOVED. DANGEROUS VOLTAGES ARE PRESENT ON THE POWER SUPPLY. THE UNIT MUST ONLY BE SERVICED BY QUALIFIED PERSONNEL.

## **2. INTRODUCTION**

### **GENERAL**

The Rx450 is designed to control 24Vac/230Vac operated pan/tilt mechanisms and the Rx550 is designed to control 24Vdc high/variable speed heads from a Panasonic RS485 telemetry control system.

The receivers can be connected using either a daisy chained or star wired RS485 network depending upon the model of Panasonic controller used. 4 wired star wired telemetry is preferred. If the control system has only a single telemetry output a BBV STARCARD/CONVERTER can be used to allow star wiring of the site.

The receiver is supplied in an IP67 rated enclosure. It will be necessary to make suitable holes in the enclosure to permit cable entry and exit. Adequately rated cable glands and or flexible conduit should be used at all times to avoid compromising the protection afforded by the enclosure as supplied. Any holes made in the enclosure for any other purpose should be sealed with a non-hardening waterproof sealant, taking care to ensure that the internal electronics are not contaminated. Enclosure mounting holes are provided at the corners of the enclosure outboard of the seal between enclosure and lid.

### 3. Rx450 Technical Specification

<b>Power Requirements</b>	230Vac or (110Vac or 24Vac as factory fitted option)
<b>Max Load</b>	5A @ 230V (1150 W)
<b>Receiver Current Draw</b>	24VA max
<b>Fuses</b>	Auxiliary fuse F2 5A T (20mm ceramic cartridge)
<b>Outputs</b>	8 single pole relays (snubbed) 1. Left Motor                      5. Autopan (Interlocked with Pan) 2. Right Motor                    6. Lights (1000W max) 3. Up Motor                        7. Wash 4. Down Motor                     8. Wipe
<b>Facilities</b>	LED readout for continual system status. Programming menu with On Screen Display.
<b>Gain</b>	<b>REMOTELY ADJUSTABLE</b> Video launch amplifier provided with cable length adjustment 12Vdc/500mA camera power provided. Colour coded outlets – live, neutral, earth and low voltage.
<b>Telemetry Signal</b>	2 or 4 wire Panasonic RS485
<b>Auto Iris Output</b>	Returns to original setting 15 seconds after key release. Level programmable from controller.
<b>Video Input</b>	1v p-p 75Ω terminated input via BNC socket.
<b>Video Output</b>	1v to 4v p-p 75Ω impedance via BNC socket.
<b>Lens Drive</b>	<b>REMOTELY ADJUSTABLE</b> Adjustable via menu between 6 – 12Vdc. Inching speed selectable via menu between 0 – 12Vdc. 1 second inching built in. Provides drive for Zoom & Focus. Each lens drive carries red and green LEDs to indicate direction and drive voltage.
<b>Presets</b>	Inputs are provided for pan, tilt, zoom & focus preset feedback pots. These are 10 bit resolution. Up to 64 full-scene presets can be stored within the receiver, i.e. pan, tilt, zoom, focus.
<b>Other Outputs</b>	RS485 Serial port available to drive advance features on selected cameras.
<b>Additional Information</b>	Autopan auxiliary output or software Random Pan Sequential preset patrol. The preset dwell is programmable individually. Datum - return to preset 1, start preset patrol or random pan after menu programmable duration of inactivity. Iris output - either direct drive for 3 motor lens or Autoiris override voltage for Seiko/Cosmicar lenses etc. 8 alarm inputs, volts free normally closed contacts. A single opening volts free contact sums the alarms either immediately or as the preset is approached. If a video transmission system is activated with the alarm output, then setting the alarm to delayed prevents unwanted frames being transmitted.
<b>Options</b>	24Vac/230Vac output is link selectable with link J3
<b>Boxed Dimensions</b>	Width: 380mm, Length: 190mm, Height: 130mm
<b>Weight</b>	3.43kg

## **Rx550 Technical Specification**

<b>Power Requirements</b>	230Vac or (110Vac or 24Vac as factory fitted option)
<b>Max Load</b>	5A @ 230V (1150 W)
<b>Receiver Current Draw</b>	Maximum of 100VA max
<b>Fuses</b>	Auxiliary fuse F2 5A T (20mm ceramic cartridge)
<b>Outputs</b>	Linear 0-24Vdc output for pan & tilt motor drive Switched 24Vdc output to drive motor brakes. Lens drive adjustable between 5-12Vdc 150mA max Total maximum of pan/tilt/lens and 24Vac auxiliary is 100VA. Switched AC output to drive Wash/Wipe/Lights(1000W max)
<b>Facilities</b>	LED readout for continual system status. Programming menu with On Screen Display.
<b>Gain</b>	<b><i>REMOTELY ADJUSTABLE</i></b> Video launch amplifier provided with cable length adjustment 12Vdc/500mA camera power provided. Colour coded outlets – live, neutral, earth and low voltage.
<b>Telemetry Signal</b>	2 or 4 wire Panasonic RS485
<b>Auto Iris Output</b>	Returns to original setting 15 seconds after key release. Level programmable from controller.
<b>Video Input</b>	1v p-p 75Ω terminated input via BNC socket.
<b>Video Output</b>	1v to 4v p-p 75Ω impedance via BNC socket.
<b>Lens Drive</b>	<b><i>REMOTELY ADJUSTABLE</i></b> Adjustable via menu between 6 – 12Vdc. Inching speed selectable via menu between 0 – 12Vdc. 1 second inching built in. Provides drive for Zoom & Focus. Each lens drive carries red and green LEDs to indicate direction and drive voltage.
<b>Presets</b>	Inputs are provided for pan, tilt, zoom & focus preset feedback pots. These are 10 bit resolution. Up to 64 full-scene presets can be stored within the receiver, i.e. pan, tilt, zoom, focus for each preset.
<b>Other Outputs</b>	RS485 Serial port available to drive advance features on selected cameras.
<b>Additional Information</b>	Software Random Pan Sequential preset patrol. The preset dwell is programmable individually. Datum - return to preset 1, start preset patrol or random pan after menu programmable duration of inactivity. Iris output - either direct drive for 3 motor lens or Autoiris override voltage for Seiko/Cosmicar lenses etc. 8 alarm inputs, volts free normally closed contacts. A single opening volts free contact sums the alarms either immediately or as the preset is approached. If a video transmission system is activated with the alarm output, then setting the alarm to delayed prevents unwanted frames being transmitted.
<b>Options</b>	24Vac/230Vac auxiliary outputs are link selectable with link J3
<b>Boxed Dimensions</b>	Width: 380mm, Length: 190mm, Height: 130mm
<b>Weight</b>	3.43kg

## CABLE CONNECTION METHOD

### Cage clamp connectors

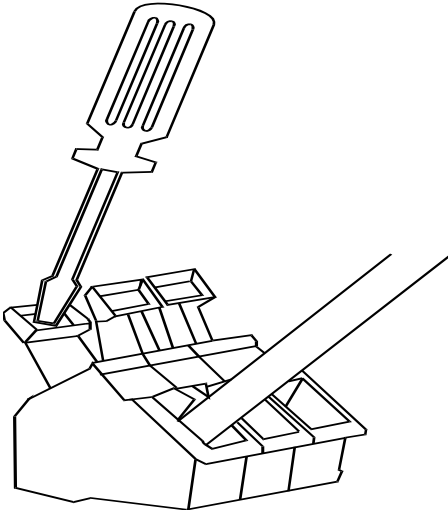

The cage clamp connector is a simple-to-use method of attaching cables to PCBs quickly and easily. Prepare cables as follows:

1. Use only cable between 0.08 and 2.5 mm<sup>2</sup>
2. Strip the cable to a length of 5 to 6 mm (0.23 in)

The correct method of attachment is as follows:

1. Press down the relevant terminal block lever with a suitable screwdriver;
2. Insert wire;
3. Remove screwdriver.

The procedure for detaching wires is the reverse of the 3 attachment steps, ensuring that **power is disconnected** before starting.

## BBV RX450 - RX550 SERIES RECEIVER SUPPLY OPTIONS AND LINKS

230Vac IN - 230Vac OUT

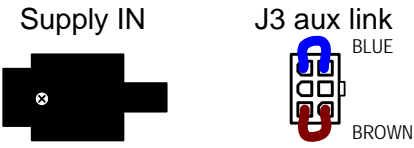

110Vac IN - 110Vac OUT (Factory fitted option)

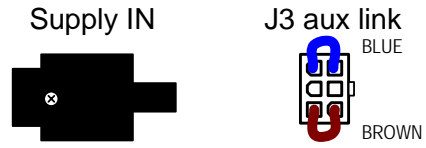

230Vac IN - 24Vac OUT

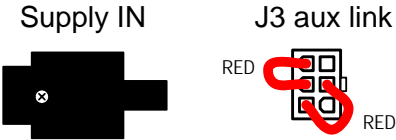

110Vac IN - 24Vac OUT (Factory fitted option)

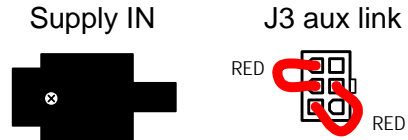

24Vac IN - 24Vac OUT RX450 Mk 2 SERIES (Factory fitted option)



24Vac IN - 24Vac OUT RX550 Mk 2 SERIES (Factory fitted option)

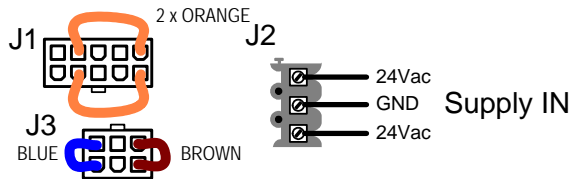

### 3. INSTALLATION

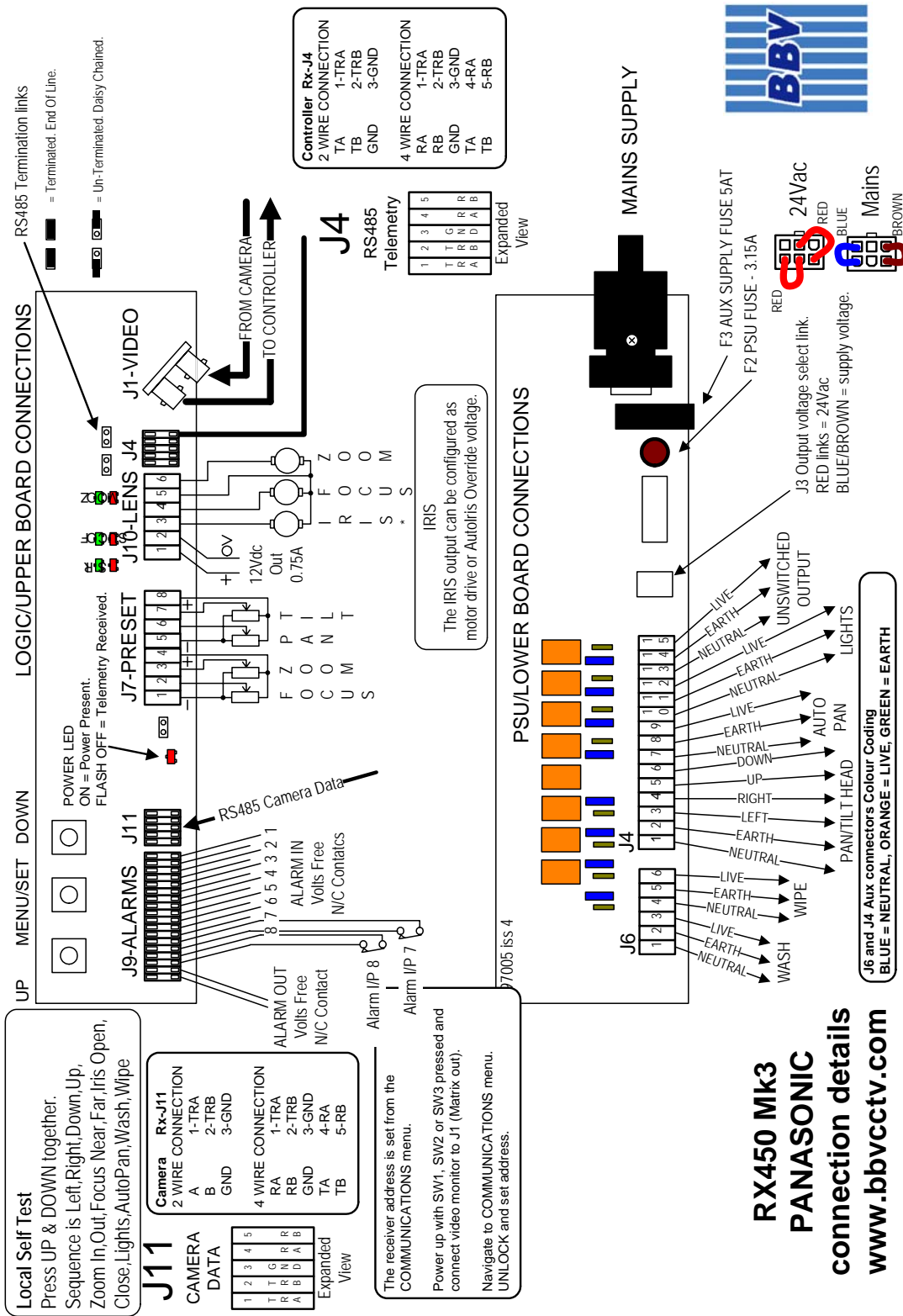

As shipped, the auxiliary and head drive outputs are set to 24Vac with the RED linked plug fitted to J3. To set the outputs to the same voltage as the receiver supply remove the red plug and replace with the plug with the BROWN and BLUE links as shown above.

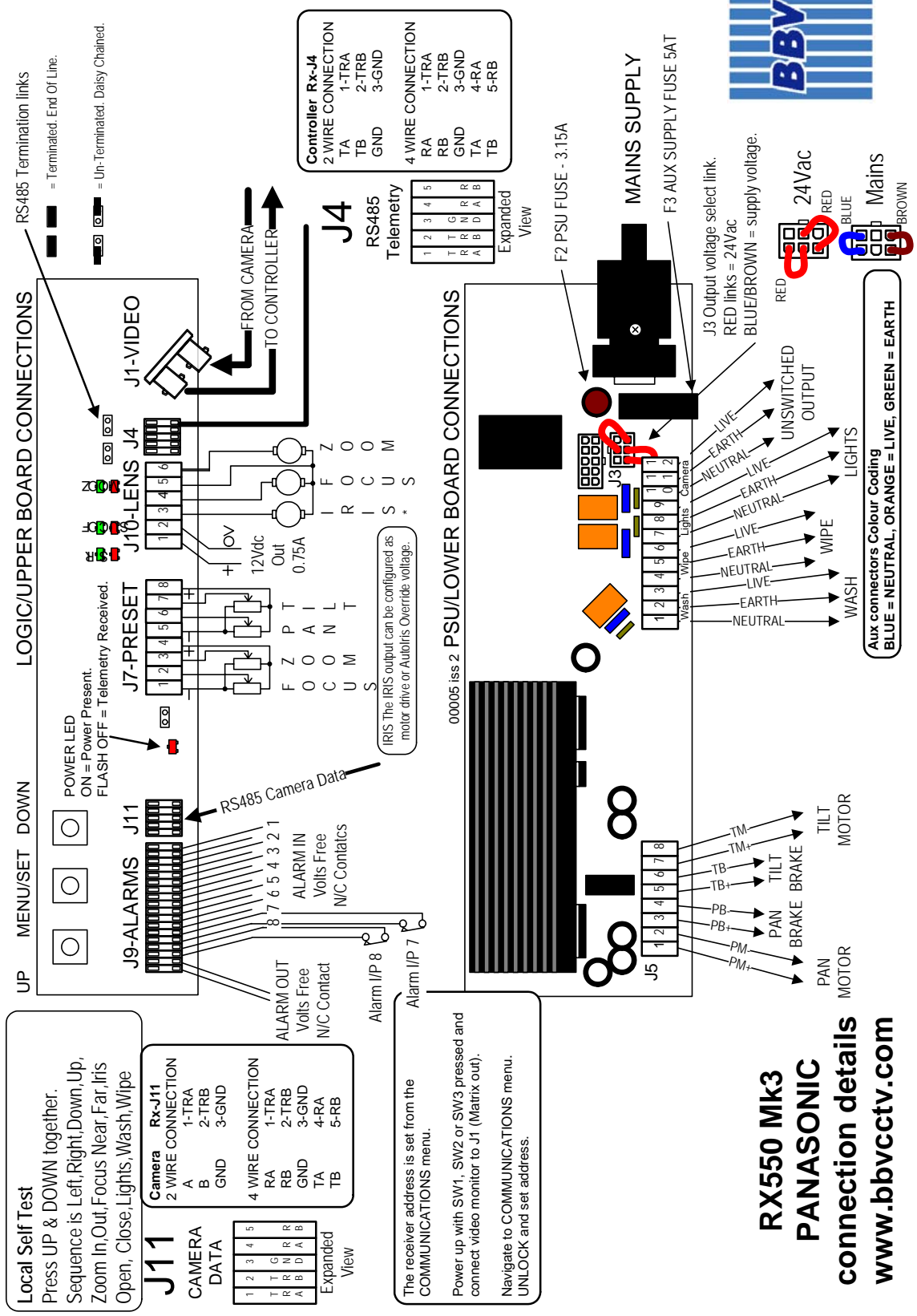

As shipped, the auxiliary outputs are set to 24Vac with the RED linked plug fitted to J3. To set the outputs to the same voltage as the receiver supply remove the red plug and replace with the plug with the BROWN and BLUE links as shown above.

**RX550 MK3**  
**PANASONIC**  
**connection details**  
**www.bbvccctv.com**

Table showing the polarity of pan/tilt head and lens outputs. Use in conjunction with head/lens manual to determine correct wiring. Ensure that the pan/tilt motor and brake wiring is correct and NOT crossed before powering up the receiver as damage could be caused. Note, that the lens outputs can be reversed from within the OPTIONS menu of the receiver menu.

Pin J5	Pan LEFT RED	Pan RIGHT GREEN
PM+	+ve	0v
PM-	0v	+ve
PB+	+ve	0v
PB-	0v	+ve

Pin J5	Tilt UP RED	Tilt DOWN GREEN
TM+	+ve	0v
TM-	0v	+ve
TB+	+ve	0v
TB-	0v	+ve

Pin J10	Zoom IN RED	Zoom OUT GREEN
ZM	-ve	+ve

Pin J10	Focus FAR GREEN	Focus NEAR RED
FC	-ve	+ve

Pin J10	Iris OPEN	Iris CLOSE
IR	-ve	+ve

# Example connection diagrams.

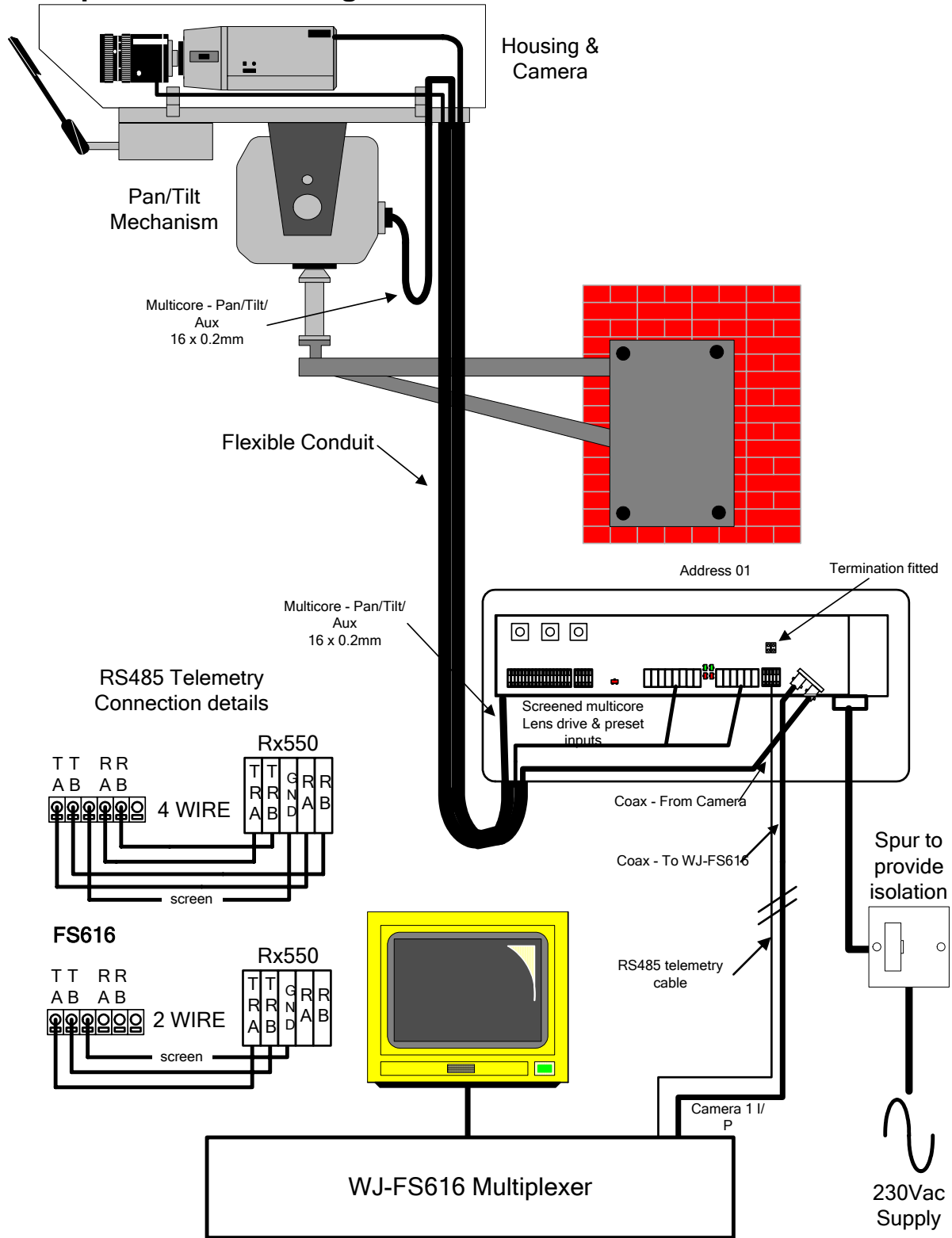

Single Rx550 with WJ-FS616



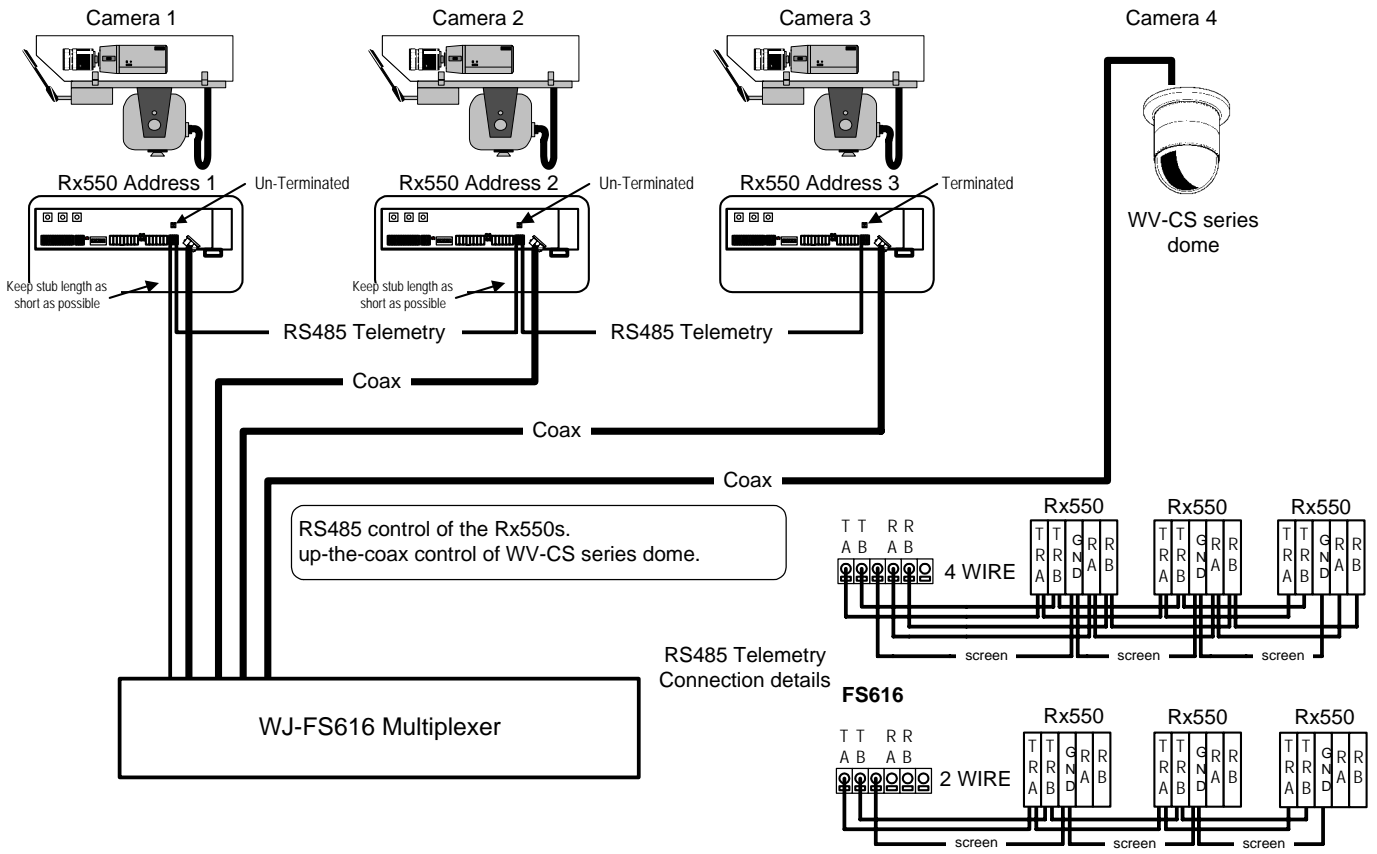

Multiple Rx550 and up-the-coax controlled dome with WJ-FS616

**Notes:**

When using a daisy chained RS485 system, the stubs must be kept as short as possible and no longer than 25cm. Intermittent and/or sluggish control can be the result of excessive stub lengths.

The receiver comprises of two pcbs mounted above an enclosed psu. The low voltage logic board is the top board whilst the 24Vdc head output and AC connections are on the middle board.

The low voltage connection can now be made to the logic board.

Each receiver on a network must have a unique address.

**RS485 Telemetry  
Connection details**

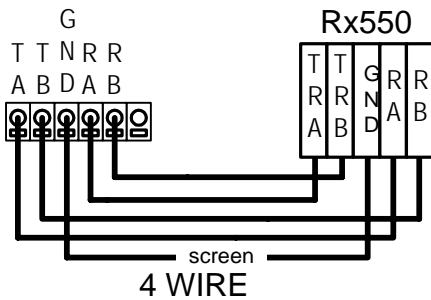

The RS485 telemetry data can operate over either 2 or 4 wire cable. The following diagram shows cable connections for 4 wire mode.

Ensure that the receiver is set to the same baud rate as the controller. The receiver default setting is 9600 baud. The receiver baud rate is set on the **BAUD RATE** line of the **MAIN/RECEIVER/COMMUNICATIONS/MENU**.

BBV recommend that 4 wire telemetry is used running at 9600 baud

## **4. SETUP**

### **Set the receiver address.**

Connect a video monitor to the video output of the receiver marked "J1 To Matrix".

a) Press any button, SW1, SW2 or SW3 and power up. The RECEIVER MENU will be displayed and COMMUNICATIONS will be flashing.

Release button and press SW2 (MENU/SET) to enter the COMMUNICATIONS menu.

b) Use SW1 (UP) or SW3 (DOWN) to move to MENU UNLOCK. Press SW2 (MENU/SET) to toggle to UNLOCK.

c) Use SW1 (UP) or SW3 (DOWN) again to move to UNIT ADDRESS and press SW2 (MENU/SET) to display the UNIT ADDRESS screen.

d) Use SW1 (UP) and SW3 (DOWN) until the required address is displayed and press SW2 (MENU/SET) to select this address and display the previous screen.

e) Use SW1 (UP) or SW3 (DOWN) to move to BAUD RATE and press SW2 (MENU/SET) to select required baud rate (BBV recommend using 9600 baud – 4 wire).

f) Use SW1 (UP) or SW3 (DOWN) to move to TELEM DATA and press SW2 (MENU/SET) to choose either 2 WIRE or 4 WIRE as required.

g) DELAY TIME can be left at OFF. Please refer to Panasonic equipment manual before adjusting this.

h) Use SW1 (UP) or SW3 (DOWN) to highlight RETURN and press SW2 (MENU/SET) to return to previous menu.

i) Use SW1 (UP) or SW3 (DOWN) to highlight RETURN and press SW2 (MENU/SET) to exit from the menu. The receiver will restart and you can now wire the unit.

### **Set the lens direction.**

After wiring the pan/tilt head and lens it is possible that the lens will drive in the opposite direction, ie pressing ZOOM TELE will cause the lens to drive out, wide. It is possible to check if the lens wiring is reversed by navigating to the ENGINEER MODE menu and selecting ZOOM IN or ZOOM OUT. If the lens drive is reversed then navigate to the ZOOM FOCUS IRIS screen of the OPTIONS menu and set to REVERSE. It is recommend that a self test is performed after changing the lens direction otherwise preset positioning will not work.

## **DIAGNOSTIC AIDS**

A single diagnostic LED labelled POWER provides indication of presence of power and also data from the multiplexer.

When the receiver is powered, the LED illuminates.

The LED will blink when the receiver has received correct telemetry data with the same address as the DIP switch address. If the telemetry data is invalid or the data is addressed to another device, the LED will remain illuminated.

Additional diagnostic aids are available in the receiver's **MAIN/RECEIVER/DIAGNOSTICS** menu. (see later)

## CABLE LENGTH COMPENSATION

The receiver incorporates a remotely adjustable high quality launch amplifier to compensate for video cable losses over extended cable distances.

The gain of the launch amplifier can be adjusted in the receiver **LAUNCH AMP GAIN** line of the **MAIN/RECEIVER/OPTIONS** menu. The gain can be varied from 0 - 255, the higher the number, the higher the gain. The default value is 0. As the amplifier gain is increased, high frequency lift is also increased.

## SELF-TEST AND DIAGNOSTIC SEQUENCE

The diagnostic system and status check, which will activate each receiver function for 2-3 seconds in turn, is activated by selecting **SELF TEST** from the receiver **MAIN/RECEIVER/TEST** menu. The self test can also be activated by pressing both the **UP** and **DOWN** buttons on the receiver top pcb simultaneously, allowing local self test of a stand alone receiver. (Please refer to earlier diagram for button positions).

The receiver OSD displays the self test progress with two status lines as shown below.

**FUNCTION** ← this line will show the current function being driven.

**Pxxxx Txxxx Zxxxx Fxxxx** ← the xxxx indicate preset pot values for pan, tilt, zoom and focus. Each value should change smoothly as the corresponding function is driven.

<b>Functions:</b>	<b>Active output</b>
PAN LEFT	J7/PM+/- PB+/-
PAN RIGHT	J7/PM+/- PB+/-
TILT DOWN	J7/TM+/- TB+/-
TILT UP	J7/TM+/- TB+/-
ZOOM IN (Lens driven fully IN)	J10/ZM
ZOOM OUT (Lens driven fully OUT)	J10/ZM
FOCUS NEAR	J10/FC
FOCUS FAR	J10/FC
AUX LAMPS	J6/LAMPS
AUX WASHER	J6/WASH
AUX WIPER	J6/WIPE
Diagnostic check complete, receiver will display a results screen and drive the head and lens for 5 seconds.	

During the self test, the presence and sense of each preset input is recorded. Following the self test the display shows if the preset inputs for pan/tilt/zoom and focus was detected. Also the pan/tilt head and lens outputs are driven for approx 5 seconds to indicate the results. If the drive led is GREEN then preset is ok and if RED then not ok.

## PROGRAMMING THE RECEIVER

An easy to use menu structure allows programming of the receiver's advanced features. The menu can be accessed either local to the receiver using the three push buttons on the receiver logic pcb or remotely using a Panasonic telemetry controller.

The three buttons on the receiver logic board allow navigation through the menu structure. Pressing the SELECT button displays the **MAIN MENU**. Pressing the UP and DOWN buttons move the flashing highlight up or down. Pressing SELECT again allows the selected sub menu to be displayed or a value to be changed. To exit the menu structure, select **EXIT** from the **MAIN MENU**. The receiver will now reset and resume normal operation.

The receiver menu can also be accessed remotely using the Panasonic controller by using the procedure used to access a camera or dome setup menu. The exact operation will vary depending upon the model of Panasonic controller used however for the FS616 multiplexer press and hold the SETUP/ESC key then tap the camera number corresponding to the receiver. The UP and DOWN keys move the flashing highlight up and down whilst the LEFT or RIGHT key is used as the select key. When the receiver menu is accessed remotely, the RECEIVER menu does not display the EXIT line. To exit from the receiver menu again use the key strokes that correspond to camera/dome menu exit. With the FS616 press and hold the FUNCTION key and tap the SETUP/ESC key.

The receiver menu structure is shown on the following pages.

# RECEIVER MENU STRUCTURE/RX550 VERSION SHOWN

```

RX550DC MAIN MENU
CAMERA
RECEIVER
EXIT
    
```

## Notes:

Navigation: UP and DOWN to move selected line. LEFT or RIGHT is used to either select the submenu or cycle options. NEXT will display the next screen of multi-screen menus and BACK will display the previous screen. RETURN will display the previous menu. EXIT quits the receiver programming allowing normal operation.

```

RECEIVER
RX550DC RECEIVER MENU
COMMUNICATIONS
PRESETS
ALARMS
OPTIONS
DIAGNOSTICS
DEFAULTS
TEST MENU
RETURN
    
```

```

COMMUNICATIONS
RX550DC COMMS MENU
BAUD RATE 9600
CONTROL DATA 4 WIRE
CAMERA DATA 2 WIRE
DELAY TIME OFF
MENU UNLOCK LOCKED
RETURN
    
```

```

PRESETS
RX550DC PRESET MENU
PATROL DWELL OM 5
DISPLAY PAT YES
PRESET NUMBER 1
DELETE ? ACTIVE
PATROL A INC IN
INDIVID DWELL NA
RETURN
    
```

```

ALARMS
RX550DC ALARM MENU 1
ALARM 1 ON
ALARM 2 ON
ALARM 3 ON
ALARM 4 ON
ALARM 5 ON
ALARM 6 ON
ALARM 7 ON
ALARM 8 ON
NEXT
    
```

```

OPTIONS
RX550DC OPTIONS MENU
LAUNCH AMP GAIN 4
MAIN LENS VOLTS 12V0
INCH LENS VOLTS 12V0
IRIS TYPE MOTOR
DC IRIS LEVEL NA
ZOOM FOCUS IRIS N N N
DATUM DELAY OM 0
WASH DELAY SECS 5
NEXT
    
```

```

DIAGNOSTICS
RX550DC DIAGNOSTICS
VERSION NO 1
AXIS FLAGS PTZF
MAX TEMP 23
DISPLAY POTS OFF
RESETS 3
WATCHDOGS 0
HOURS USE 2
PRESET CALLS 134
RETURN
    
```

```

DEFAULTS
RX550DC DEFAULTS MENU
RESET RECEIVER
CLEAR ALL PRESETS
RETURN
    
```

```

TEST MENU
RX550DC TEST MENU
SELF TEST
LENS OFFSET 12
MOTOR OPTIONS
NET TRAFFIC ON
RETURN
    
```

```

PATROL DWELL
PATROL DELAY
MINUTES 0 SECONDS 5
    
```

```

NEXT
RX550DC ALARM MENU 2
DISPLAY ALARM ON
DELAYED ALARM OFF
BACK RETURN
    
```

```

LAUNCH AMP GAIN
LAUNCH AMP SETTING
4
    
```

```

AXIS FLAGS
RX550DC AXIS LOCKED
PAN PRESENT
TILT PRESENT
ZOOM ABSENT
FOCUS ABSENT
PAN DIR NORMAL
TILT DIR REVERSED
ZOOM DIR NORMAL
FOCUS DIR NORMAL
RETURN DO NOT ALTER
    
```

```

RESET RECEIVER
RX550DC DEFAULTS
ARE YOU SURE
RESET RECEIVER
CANCEL
    
```

```

LENS OFFSET
LENS STOP 12
    
```

```

PRESET NUMBER
ACTIVE PRESET 1
    
```

```

MAIN LENS VOLTS
LENS HIGH SPEED
12V0
    
```

```

RX5. CLEAR ALL PRESETS
ARE YOU SURE
CLEAR PRESETS
CANCEL
    
```

```

MOTOR OPTIONS
RX550DC MOTOR OPTIONS
MAX PAN 255
MIN PAN 15
MAX TILT 255
MIN TILT 50
MAX PRE PAN 255
MAX PRE TILT 255
RETURN
    
```

```

DELETE
CHECK DELETE
ARE YOU SURE
DELETE PRESET
CANCEL
    
```

```

INCH LENS VOLTS
LENS INCH SPEED
6V0
    
```

```

INDIVID DWELL
PRESET DELAY IN PATROLA
MINUTES 0 SECONDS 0
    
```

```

ZOOM FOCUS IRIS
RX550DC LENS DRIVE
ZOOM NORMAL
FOCUS NORMAL
IRIS NORMAL
RETURN
    
```

```

DATUM DELAY
PATROL DELAY
MINUTES 0 SECONDS 0
    
```

```

NEXT
RX550DC OPTIONS MENU 2
RAND PAN DELAY 1
DISPLAY AUX OSD DISP
TEXT ON LINE 10
BACK RETURN
    
```

The RX450 structure is similar but doesn't have the motor speed options as the motor speed is set by the internal gearing of the head.

## THE RECEIVER MENU SYSTEM IN DETAIL

Please refer to the menu structure on the previous page to help navigation through the menu structure.

### COMMUNICATIONS

#### RX550 DC COMMS MENU

UNIT TYPE	PANASONIC
UNIT ADDRESS	1
BAUD RATE	9600
TELEM DATA	4 WIRE
DELAY TIME	OFF
MENU UNLOCK	LOCKED
RETURN	

This is the address between 1 and 255 and must be unique  
RS485 baud rate 1200/2400/4800/9600/19200

2 WIRE/4 WIRE RS485 network from Panasonic controller  
TX/RX delay 10/20/40/100mS/OFF for use with RF links etc

Must be set to UNLOCKED to allow setting of above

Return to RECEIVER menu

### PRESETS

#### RX550DC PRESET MENU

PATROL DWELL	OM 5
DISPLAY PAT	YES
PRESET NUMBER	1
DELETE ?	ACTIVE
PATROL A INC	IN
INDIVID DWELL	NA
RETURN	

Dwell in minutes & seconds during preset patrol

Display preset number during patrol (YES/NO)

Toggle current preset (1 - 32)

Delete current preset, DEL if preset not present

Include preset in patrol (IN/OUT)

Override patrol dwell for this preset minutes & seconds

Return to RECEIVER menu

### ALARMS

#### RX550DC ALARM MENU 1

ALARM 1	ON
ALARM 2	ON
ALARM 3	ON
ALARM 4	ON
ALARM 5	ON
ALARM 6	ON
ALARM 7	ON
ALARM 8	ON
NEXT	

Each local alarm input can be disable or enabled individually.

Setting to OFF disables the alarm input and setting to ON enables the alarm input

Display the ALARM MENU 2

*NEXT*

**RX550 DC ALARM MENU 2**

**DISPLAY ALARM ON**  
**DELAYED ALARM OFF**  
**ALARM 8 NORMAL**

**BACK RETURN**

Receiver displays ALARM message when alarm active if ON OFF/ON. When set to ON, the alarm message is generated as the head approaches it's preset position to prevent a triggered video transmission system from sending 'blurred' frames. When set to OFF, the alarm output is active as soon as an alarm occurs.

Alarm 8 can be set to GLOBAL to disable alarm 1-7  
BACK displays ALARM 1 and RETURN displays RECEIVER menu

*OPTIONS*

**RX550DC OPTIONS MENU**

**LAUNCH AMP GAIN 0**  
**MAIN LENS VOLTS 12V0**  
**INCH LENS VOLTS 12V0**  
**IRIS TYPE MOTOR**  
**DC IRIS LEVEL NA**  
**ZOOM FOCUS IRIS N N N**  
**DATUM DELAY OM 0**  
**WASH DELAY SECS 5**  
**NEXT**

Coax cable compensation 0-255, 255 = maximum gain  
Lens drive voltage 3-12V, set to suite lens  
Set the drive voltage for first second of travel.  
Set lens iris type for autoiris override or 3 motor lens  
Sets iris voltage range for Seiko or Cosmucar lens  
Allow each lens function to be reversed  
Time in minutes/seconds to return to preset 1, 0=never  
Seconds that WASH output is active following WIPE  
Display the OPTIONS MENU 2

*NEXT*

**RX550 DC OPTIONS MENU 2**

**RAND PAN DELAY 1**

**DISPLAY OPTIONS**  
**TEXT ON LINE 10**  
**ON POWER UP NO ACTION**  
**CAMERA TYPE 4 WIRE**  
**SIN COS IP NOT FITTED**

**BACK RETURN**

Random pan delay,1=fast,10=slow,0=AUTOPAN which requires an optional card within the pan/tilt head.  
Display the DISPLAY OPTIONS screen.  
1-10. Position of status on screen, 1=top,10=bottom  
Select either PRESET 1/RANDOM PAN/PATROL 1/NO ACTION  
Choose 2/4 wire comms if using Panasonic camera  
FITTED using continuous rotation pan with sin/cos pots  
  
BACK to OPTIONS 1 or RETURN to RECEIVER MENU

*DIAGNOSTICS*

**RX550 DC DIAGNOSTICS**

**VERSION NO 18**  
**PRESET FLAGS PTZF**

**DISPLAY POTS OFF**  
**RESETS 3**  
**WATCHDOGS 0**  
**HOURS USE 2**  
**PRESET CALLS 134**  
**RETURN**

Receiver software version  
Indication of preset input status see PRESET FLAGS below

Display preset pot values.Useful during diagnosis work  
Number of receiver power-ups.Useful diagnosis tool  
Number of processor watchdogs(supply glitches)  
Hours receiver powered  
Number of preset calls  
RETURN to RECEIVER MENU

**PRESET FLAGS**

<b>PRESET FLAGS LOCKED</b>	
<b>PAN</b>	<b>YES</b>
<b>TILT</b>	<b>YES</b>
<b>ZOOM</b>	<b>NO</b>
<b>FOCUS</b>	<b>NO</b>
<b>PAN DIR</b>	<b>NORMAL</b>
<b>TILT DIR</b>	<b>REVERSED</b>
<b>ZOOM DIR</b>	<b>NORMAL</b>
<b>FOCUS DIR</b>	<b>NORMAL</b>
<b>RETURN</b>	<b>DO NOT ALTER</b>

Toggle to UNLOCK to alter settings.

During a self test, the receiver senses the presence and direction of preset input voltages. Should the receiver incorrectly sense the presence or direction then this menu allows manual setting. Toggle between YES/NO to enable/disable presets for each movement axis. The direction can be toggled between NORMAL or REVERSED if the head/lens drives in the wrong direction during a preset call.

Please use with caution to prevent mis-operation.

RETURN to DIAGNOSIS MENU

**DEFAULTS**

**RX550DC DEFAULTS MENU**

**RESET RECEIVER**

**CLEAR ALL PRESETS**

**RETURN**

These two items should be used with extreme caution!

Set receiver to factory defaults. All preset/patrol settings etc will be cleared.

Erase ALL preset positions only.

A second menu will be displayed to display an ARE YOU SURE message!

RETURN to RECEIVER MENU

**TEST MENU**

**RX550 DC TEST MENU**

**SELF TEST**

**ENGINEER MODE <PCB ONLY>**

**MOTOR OPTIONS**

<b>ZOOM FACTOR</b>	<b>25</b>
<b>NET TRAFFIC</b>	<b>OFF</b>

**RETURN**

Starts receiver self test procedure displays the ENGINEER MODE screen

Displays various pan/tilt speed options 25-100 lower figure slower pan/tilt when zoomed in BBV use to display RS485 telemetry commands when ON

RETURN to RECEIVER MENU

**ENGINEER MODE**

**ENGINEER MODE**

<b>PAN LEFT</b>	<b>PAN RIGHT</b>
<b>TILT UP</b>	<b>TILT DOWN</b>
<b>ZOOM IN</b>	<b>ZOOM OUT</b>
<b>FOCUS NEAR</b>	<b>FOCUS FAR</b>
<b>IRIS OPEN</b>	<b>IRIS CLOSE</b>
<b>WASH</b>	<b>WIPE</b>
<b>LIGHTS</b>	<b>AUTOPAN</b>
<b>RETURN</b>	

used to allow each output to be tested individually

Select the desired output and press SW2.

The output will drive until SW2 is released.

if ZOOM/FOCUS/IRIS are driving in reverse use the OPTIONS menu and toggle between REVERSE/NORMAL

AUTOPAN does nothing with RX550

RETURN to TEST MENU

*MOTOR OPTIONS*

**RX550DC MOTOR OPTIONS**

**MAX PAN            255**

**MIN PAN            15**

**MAX TILT          255**

**MIN TILT          50**

**MAX PRE PAN      255**

**MAX PRE TILT     255**

**RETURN**

These settings allow the receiver to be tailored to different pan/tilt motors. The MIN/MAX values set the minimum and maximum speeds during manual control. 255 is maximum speed and 0 is minimum.

If the minimum is too low, the head may stall at low speeds.

To increase pan/tilt head life, the pan and tilt speeds can be reduced during preset calls. Again take care that the head doesn't stall.

RETURN to TEST MENU

## Receiver USER GUIDE

Select the camera to control using the Panasonic controller.

Manual control of the pan/tilt head and lens is accomplished by pressing the relevant key or moving the joystick. Multiple functions can be controlled simultaneously. E.g. Pan Left and Tilt Down.

To move the pan/tilt head to a preset position, refer to the Panasonic controller manual. The receiver supports preset 1 – 64.

If this preset has been programmed, the head/lens will move to show the preset position.

*Note: preset functions require a preset head for pan/tilt positioning and a preset lens for zoom/focus positioning.*

Receiver OSD displayed.

W Wipe auxiliary output is active

\* Lights auxiliary output is active

↔ Random Pan is running

Auxiliary functions are accessed using the AUTOPAN menu. This is displayed when the AUTO key is pressed and appears as follows:

<b>AUTOPAN</b>	
<b>ALARM MENU</b>	
<b>RANDOM PAN</b>	<b>OFF</b>
<b>PATROL</b>	<b>OFF</b>
<b>LIGHTS</b>	<b>OFF</b>
<b>WASH/WIPE</b>	<b>OFF</b>
<b>PROG PRESETS</b>	<b>OFF</b>
<b>CANCEL</b>	

Pressing the AUTOPAN key displays this menu  
Use the UP/DOWN keys to choose a line and LEFT or RIGHT to either toggle ON/OFF or display ALARM MENU

Display ALARM menu to enable/disable alarm inputs  
Start RANDOM  
Start preset patrol  
Toggle the LIGHTS auxilliary ON/OFF  
Toggle WIPE & WASH auxilliary.WASH time set in OPTIONS  
ON=Program presets, OFF=Normal  
Quit menu

When RANDOM PAN is selected, the head starts a random panning sequence until either a manual command or a local alarm occurs. If DISPLAY AUX OSD is set to DISP in the OPTIONS 2 menu then an arrow is displayed showing the direction of pan travel.

**PATROL:** Starts the preset patrol. If DISPLAY PAT is set to YES the receiver displays P and the current preset number. Pressing one of the pan/tilt keys will stop the patrol and manual control is resumed.

LIGHTS: The lights auxiliary output is turned on/off with this line. If WIPE/LIGHTS/AP is set to YES in the DISPLAY OPTIONS menu from the OPTIONS 2 menu then a \* symbol is displayed whilst the lights are on.

WASH/WIPE: The WIPE auxiliary output is turned on and the WASH auxiliary output is activated for the time set in the OPTIONS menu. If WIPE/LIGHTS/AP is set to YES in the DISPLAY OPTIONS menu from the OPTIONS 2 menu then a W is displayed whilst the lights are on.

If ALARM STATUS is set to YES in the DISPLAY OPTIONS menu any open local alarm inputs will be displayed. This is useful for remotely links to show any active/faulty alarm input.

ALARM MENU: This item displays the ALARM MENU allowing the local alarms to be enabled/disabled individually.

		<i>ALARMS</i>
<b>RX550DC ALARM MENU 1</b>		
<b>ALARM 1</b>	<b>ON</b>	Each local alarm input can be disable or enabled individually. Setting to OFF disables the alarm input and setting to ON enables the alarm input
<b>ALARM 2</b>	<b>ON</b>	
<b>ALARM 3</b>	<b>ON</b>	
<b>ALARM 4</b>	<b>ON</b>	
<b>ALARM 5</b>	<b>ON</b>	
<b>ALARM 6</b>	<b>ON</b>	
<b>ALARM 7</b>	<b>ON</b>	
<b>ALARM 8</b>	<b>ON</b>	
<b>NEXT</b>		Return to the AUTOPAN MENU

Use the UP and DOWN keys to select an alarm input. The Left or Right key will toggle the state from ON/OFF. When the alarms have are configured correctly, select the NEXT line to resume normal operation.

*Alarm inputs are normally closed. The alarm is activated when contact open and the receiver drives the head to the preset position corresponding to the alarm input.*

PROG PRESETS: Allows preset positions to be programmed. The receiver will display PROGRAM after the menu disappears. In this mode 'goto preset' commands are used to program a preset position. Move the pan/tilt head and lens to the scene to be saved.

*Please ensure that all the directions ARE NOT AT A LIMIT STOP as intermittent preset operation could occur.* Press PRE-POSI on the CURSOR/CAMERA CONTROL keypad followed by the preset number required on the CAMERA/PRESET POSITION keypad. Several preset positions can be programmed whilst PROGRAM is displayed. To return to normal operation, go into the menu and set PROG PRESET to OFF. The receiver no longer displays PROGRAM and normal control is resumed.

*Note: preset functions require a preset head for pan/tilt positioning and a preset lens for zoom/focus positioning.*

Blank for your notes

Blank for your notes

## Other BBV products.

Product	Description
<b>TX300</b>	Single camera desktop telemetry transmitter with coax & 20mA telemetry, Pan/Tilt/Lens & Lights
<b>TX400</b>	As TX300 inc Wash, Wipe, Autopan, 8 presets, preset patrol.
<b>TX400DC</b>	As TX400 including joystick for proportional Pan/Tilt control.
<b>TX1000</b>	8 or 16 camera, 2 monitor telemetry transmitter. Up to 2 keyboards and options for alarm inputs and 20mA telemetry.
<b>TX1500</b>	Mid size matrix 16 – 96 camera, 8 monitor. Up to 4 control positions (keyboard & remote control) options for alarms, remote control, coax and RS485 telemetry.
<b>FBM range</b>	Large size matrix. Configurable up to 1024 cameras and 64 monitor outputs. Up to 8 control positions (keyboard & remote control) options for alarms, remote control RS485 telemetry with various options.
<b>RX100</b>	Dome Interface with options to drive a large library of dome cameras. Coaxial and 20mA telemetry.
<b>RX200</b>	AC receiver for Pan only heads or static cameras, Wash/Wipe/Lights. Coaxial and 20mA telemetry.
<b>RX300</b>	AC receiver for Pan/Tilt/Zoom/Focus/Iris Override and 1 Auxiliary output. Coaxial and 20mA telemetry.
<b>RX400P</b>	AC full function receiver. PTZFI 4 Auxiliary outputs, 16 presets. Coaxial and 20mA telemetry.
<b>RX45X - RX55X</b> Multi protocol RS485 and BBV coax	RS485 and BBV coax controllable AC and DC receivers. These receivers are controlled from an expanding choice of RS485 protocols as listed below. 110/230Vac supply. PTZFI, 32 presets, preset patrol, 8 local alarm inputs, 12V 500mA supply output. OSD for remote diagnostics. 3 Auxiliary outputs. Optional Privacy board. BBV RS485 and COAX, PELCO P/D RS485, VCL RS485, PHILIPS RS485 (OPTIONAL BI-PHASE INPUT), DENNARD RS485
<b>RX450/550</b>	PANASONIC RS485 Protocol only version of RX45X/55X.
<b>STARCARD</b>	8 * RS485 output with option of protocol conversion. STARCARD/CONVERTER
<b>ACCESSORIES</b>	TxLD (bidirectional RS422-RS232 converter) 98005 (bidirectional 20mA-RS232 converter)